

PENSKE
RACING SHOCKS®



PS-75DBDRAG-STRUT
Strut, Pro-Drag, Dual-Bleed

TECHNICAL MANUAL

Main Office
150 Franklin St. • P.O. Box 1056
Reading, PA 19603
(610) 375-6180 • (610) 375-6190 Fax

Table of Contents:

Introduction	p.3
Terminology	p.4
Getting Started	p.5
Adjusters	p.5
Rebound Adjuster	p.6
Compression Adjuster	p.7
Factory Settings	p.8
Warnings	p.9
Track Tuning	p.10
Troubleshooting	p.10
Assembly	p.11
Parts List	p.12
Technical Support	p.13

Introduction

Thank you for your purchase of your new Penske Racing Shocks Pro Drag Strut!

The Pro Drag Strut is the result of many years of development in drag racing combined with 20+ years of shock absorber technology used with success in the highest levels of Motorsport. The Pro Drag Strut is intended for use (and is approved for competition) in NHRA Pro Stock, NHRA Pro Mod, ADRL, IHRA Pro Stock, and IHRA Pro Mod classes. Essentially, any double A-arm vehicle can use the Pro Drag Strut.

All of the fundamental attributes found in any Penske Racing Shock have been incorporated into the Pro Drag Strut including:

- *Standard Penske 55mm bore size which allows use of wide array of piston types*
- *Low-friction shaft and piston seals*
- *Hard anodized, 7000 series aluminum bodies and components for superior durability and performance*
- *Hard-chromed 4130 main shaft for strength, durability, and low breakaway friction*
- *Durable ACME thread body that allows quick adjustment of spring preload (.100" per turn)*
- *Penske unique dual-bleed adjuster for independent tuning of compression and rebound in easy-to-access shaft adjuster*
- *Simple, in-line design for lightest weight*
- *Winning heritage – Penske Racing Shocks continue to help our customers win races and championships in all forms of Motorsport.*
- *Made in U.S.A. – The Pro Drag Strut has been 100% designed, machined, assembled, and tested for quality in the United States.*



Terminology:

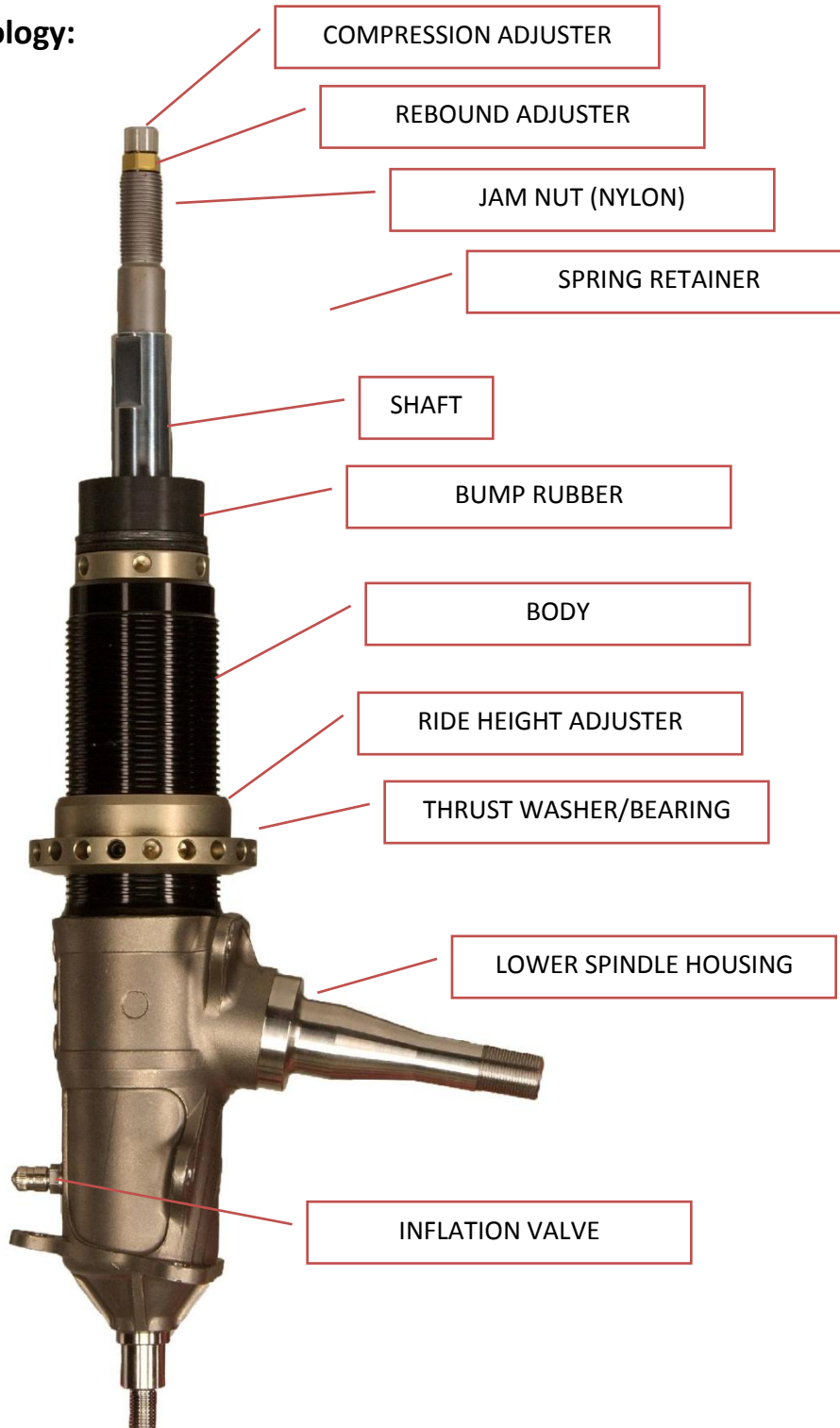

Getting Started:

The Pro Drag Struts are set from the factory at recommended starting settings for your application. They are pressurized and ready to go. The starting pressure for the Pro Drag Strut is 75 psi.

Adjusters:

The dual-bleed adjusters are nested within the same mechanism. This means that when making a compression adjustment, the rebound adjuster will NOT turn. When making a rebound adjustment, the compression knob will rotate. This is normal. If the rebound adjuster turns when you are making a compression adjustment, you may be side loading the knob or you may have “locked” them together. If this happens, simply put a ½ wrench on the rebound adjuster flats and break the compression adjuster loose with a 5/16 Allen by turning counter-clockwise.

The Dual-Bleed adjuster mechanism provides the following ranges:

- Compression Adjuster (5/16 Allen) / Silver Adjuster: 20 clicks
(stiffer = clockwise; 0 = full hard, -20 = full soft)
- Rebound Adjuster (1/2 Hex) / Gold Adjuster: 30 clicks
(stiffer = clockwise; 0 = full hard, -30 = full soft)

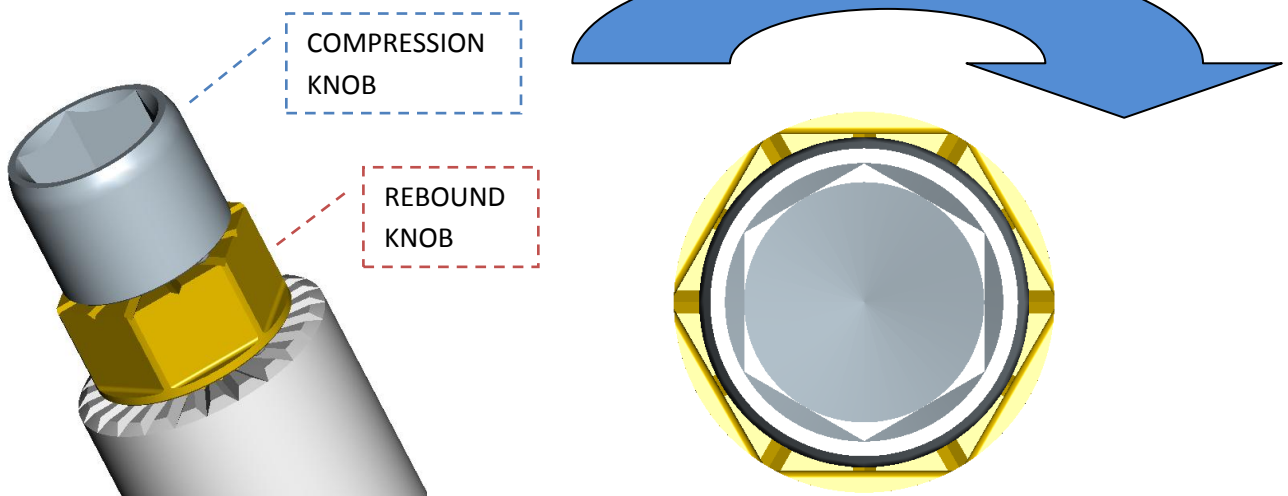

Top View of Strut

Do not over-tighten the adjusters. When making adjustments, they will have a positive stop. In order to close off the bleed, you do not need to continue to turn the knob for it to seal.

To adjust, follow the procedure as follows (if this procedure is not followed in the recommended sequence, the intended settings may not be achieved in practice):

To Set Adjusters:

- 1.) Turn REBOUND Hex full clockwise until it stops.
- 2.) Turn COMPRESSION Allen full clockwise until it stops.
- 3.) Turn the COMPRESSION Allen counterclockwise to desired setting.
- 4.) Turn the REBOUND Hex counterclockwise to desired setting.
- 5.) During track tuning, simply turn adjusters as needed until the adjuster stops which would signify you are at the end of the adjustment range.

Adjustment Range: REBOUND (30 Clicks)

The rebound adjustment range is extensive but within the typical tuning window for all chassis and track conditions. The adjuster has most effect in the 0-5 in/sec velocity range of the strut.

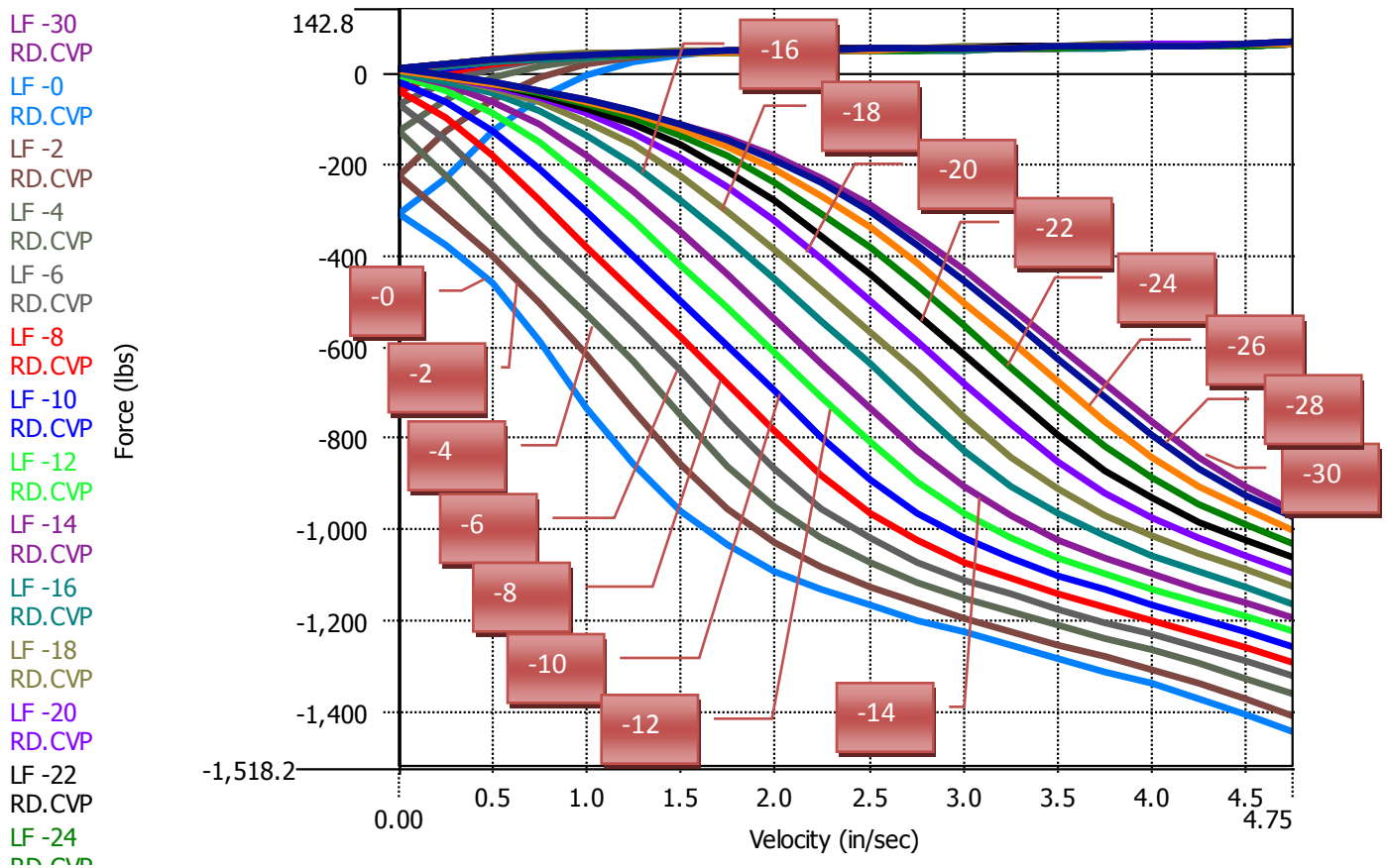

Adjustment Range: COMPRESSION (20 Clicks)

The adjustment range of the compression adjuster works primarily in the low-speed area of the velocity spectrum. This is from 0-2 in/sec in strut velocity. Testing has shown that this is the area where transients to the chassis can be tuned depending on driver preference and down-track aero performance.

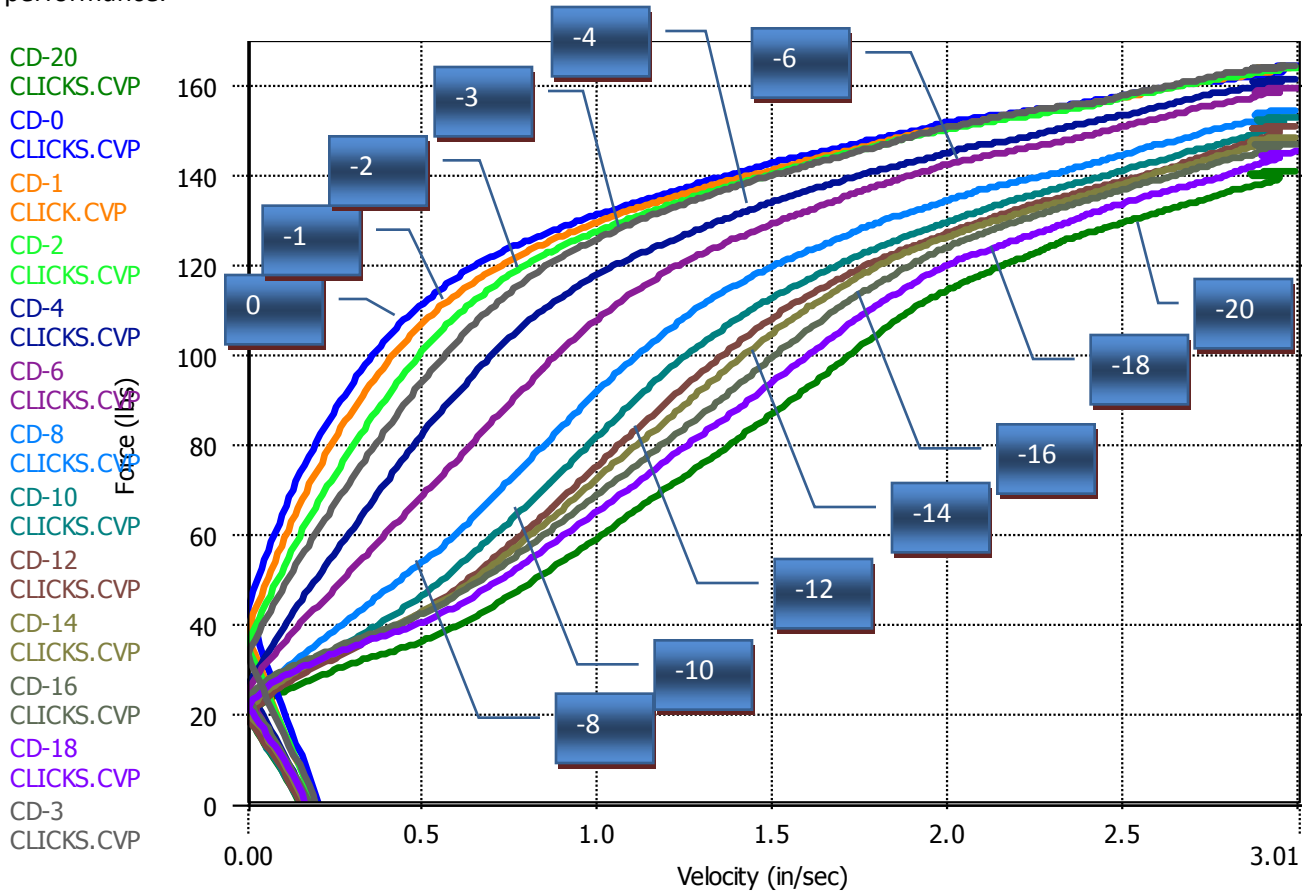

Factory Settings:

Adjusters:

- -20 (Compression)
- -10 to -15 (Rebound) depending on application

Gas Pressure:

- 75 psi

LF -13
RD.CVP

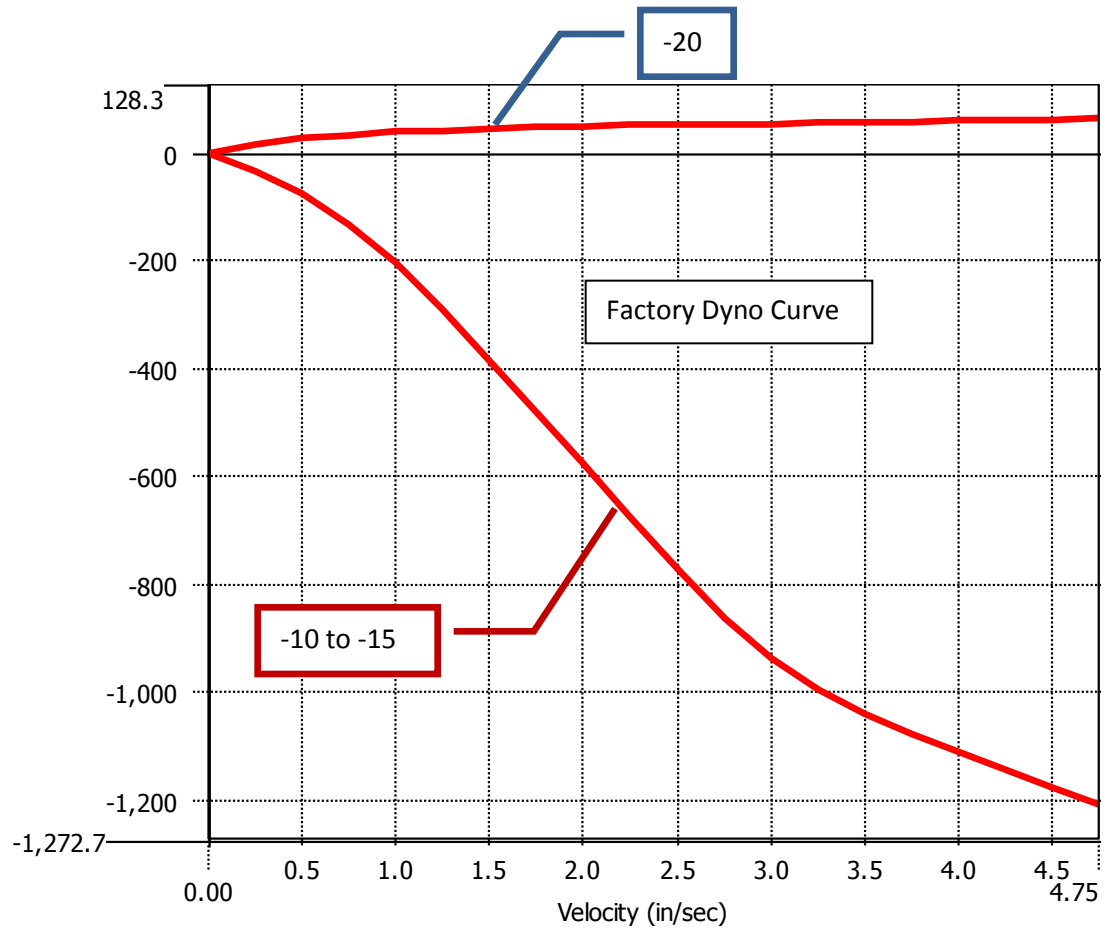

Warnings:

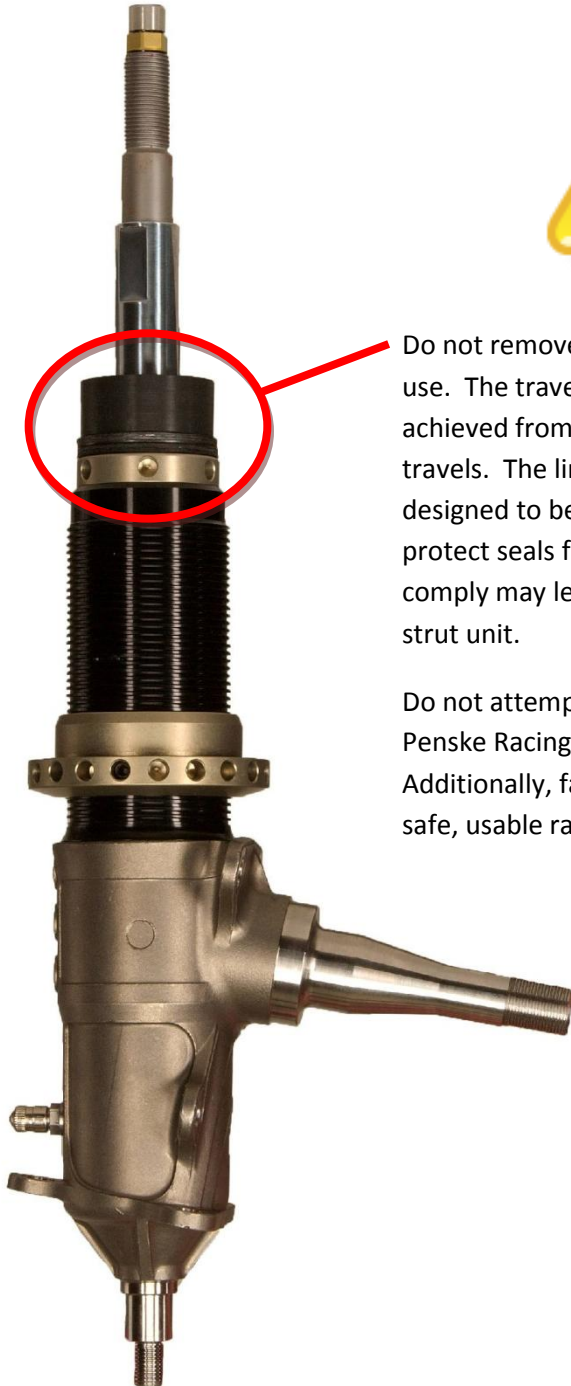

Do not remove the (2) packers and bump rubber from strut in use. The travel requirements of the Pro Drag Strut were achieved from multiple years of testing and observance of strut travels. The limiting devices installed on the strut (which are designed to be 1" in total height) allow sufficient travel and protect seals from the tightening flats on the shaft. Failure to comply may lead to improper function of the strut seals and strut unit.

Do not attempt to open the strut unit without consultation from Penske Racing Shocks. Contents are under pressure. Additionally, factory baseline piston/shim set-up provides a safe, usable range of adjustment for all applications.

Track Tuning:

Compression Adjuster:

Compression adjustments control how much the front of the car will compress as the car travels down track. This will gain aero performance which will improve MPH. Compression will also help keep the car more stable or level as the front wheels return to the track after the initial launch. If the compression is too stiff, the car will go into a “pogo affect” and the rear tires will lose traction and spin.

Rebound Adjuster:

Rebound adjustments control the attitude and weight transfer of the car as it leaves the starting line. The stiffer or slower the rebound, the more the car will “squat” initially which will induce bite into the tire. The softer or faster the rebound, the more the car will pick the front end up and travel out off the starting line before weight can be transferred to the rear tires. This increases wheel speed due to the lack of initial bite in the tire.

Gas Pressure:

We do not recommend altering the factory gas pressure setting of 75 psi.

Troubleshooting:

Signs of Fluid:

If the area around the shaft bearing and shaft exhibits a small amount of moisture, this is normal. In order to reduce friction in the system, seal squeezes are slightly relaxed which serves the purpose to allow a small amount of fluid to be wicked onto the shaft when the strut operates. If you see excessive amount of fluid that may “pool” on the top of the shaft bearing, you may have a seal problem. Contact your Penske representative at once.

Loss of Gas Pressure:

If the strut for some reason loses its gas charge, the data may show that the velocity of that corner is much reduced. Also, a tell-tale sign of reduced or no gas pressure is that the strut (without a spring) when compressed, will not return to its fully extended position.

Failure of Shaft to Extend:

If the strut has lost pressure or lost excessive fluid, you may find that the strut shaft does not extend fully when compressed. In some situations, you may need to physically “pull” the shaft out in order for it to reach full extension.

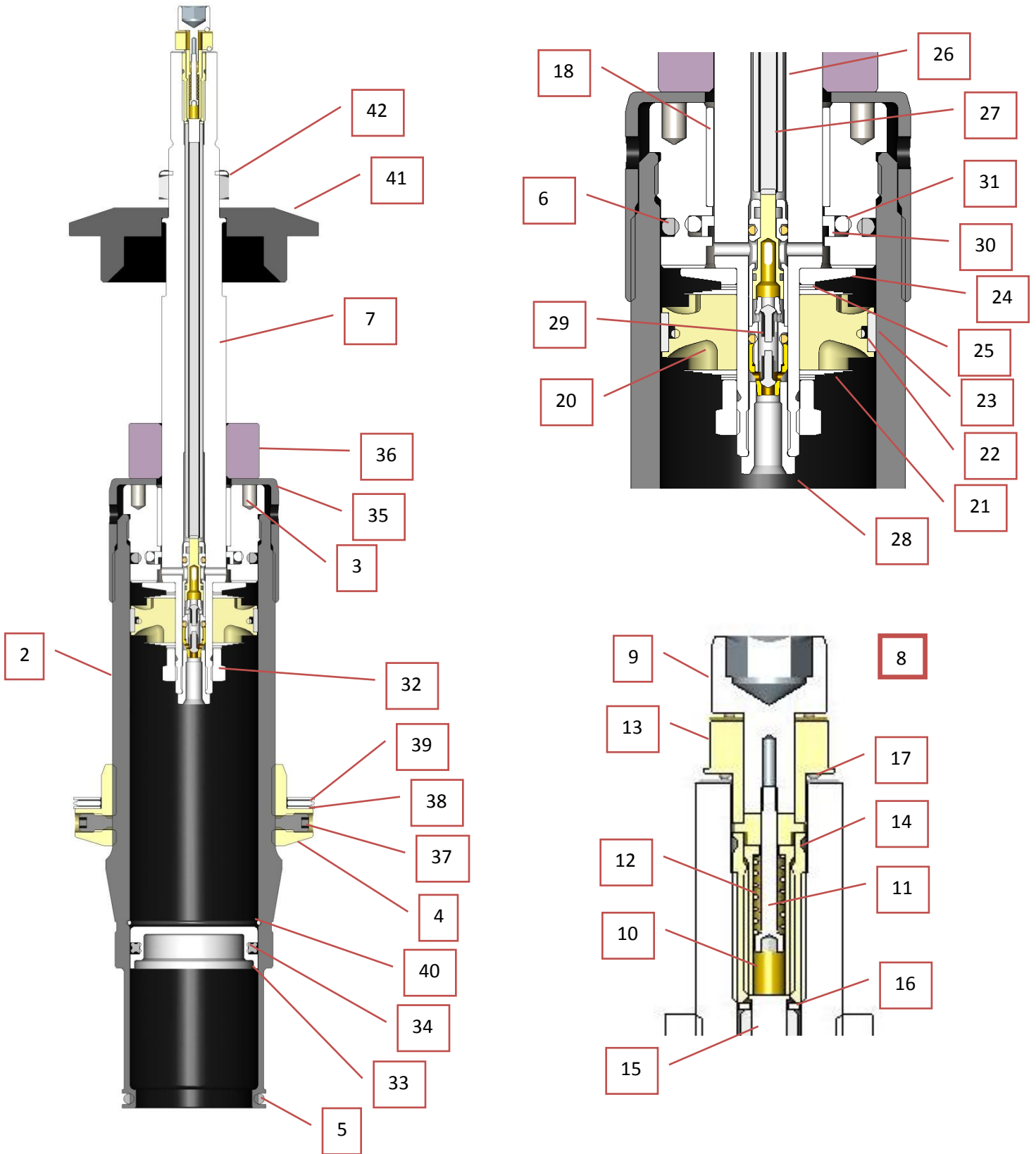

KEY	PART NUMBER	DESCRIPTION
2	BD-DRAG-STRUT	BODY, DRAG STRUT
3	SB-DRAG-STRUT	SHAFT BEARING, DRAG STRUT
4	RH-DRAG-STRUT	RIDE HEIGHT ADJUSTER, DRAG STRUT, 2.50"
5	OR-2223-B	O-RING, BUNA, 70 DUROMETER
6	OR-2221-B	O-RING, BUNA, 70 DUROMETER
7	SH-22MM-DRAG	SHAFT, DRAG STRUT, 22MM, "L" = 8.667"
8	AS-2000SC-DRAG	ASSEMBLY, DUAL-BLEED KNOBS, DRAG STRUT
9	KN-PC997-CD	KNOB, D/B COMPRESSION, DRAG STRUT
10	SC-DBCD-MK2	SCREW, D/B COMP ADJ. MK2
11	SC-DB-MK2	SCREW, SHCS 1-72 X 3/4"
12	SP-20	SPRING
13	KN-PC997-RD	KNOB, D/B REBOUND, DRAG STRUT
14	SC-DBRD-MK2	SCREW, D/B RD ADJ. MK2
15	MR-DBCD-MK2	METERING ROD, D/B CD ADJ MK2
16	VW-26130-156	WASHER, .262 X .156 X .030 VALVE
17	BA-0625-ST	BALL, 1/16" STEEL
18	BU-2225DU	BUSHING, DU 22MM X 25MM
20	PI-HF14005	PISTON, 1 DEG/4 DEG HIGH-FLOW, LINEAR
21	VS	VALVE STACK, COMPRESSION AND REBOUND
22	OR-2028-B	O-RING, BUNA, 70 DUROMETER
23	PB-55	PISTON BAND, 55MM
24	VW-100	TOP-OUT PLATE, MACHINED
25	VS	CONSTANT SHIMS
26	MR-10-5339	METERING ROD, D/B INNER, .125"
27	MR-12-5579	METERING ROD, D/B OUTER, .250"
28	JT-DBRD	JET, DB R/D ADJ.
29	JT-DBCOMP-MK2	JET, D/B ASSEMBLY, COMPLETE
30	SL-22MM	STEPSEAL, 22MM
31	OR-2215-B	O-RING, BUNA, 70 DUROMETER
32	NT-02R	RING NUT, .500 X 20, .440" LONG
33	PI-75	PISTON, 7500 FLOATING
34	OR-4221-B	QUAD RING, BUNA, 70 DUROMETER
35	CP-DRAG-22MM	SAFETY CAP
36	BR-90-175	BUMP RUBBER, 1.75" X .635", 90 DUROMETER
37	SC-M6M8-S	SCREW, SHCS M6 X 8MM STEEL W/ NYLON TIP
38	VW-06	THRUST PLATE, 2.50" ID
39	VW-08	THRUST WASHER, 2.50" ID
40	RR-06	WIRE RING, .062 WIRE DIAMETER X 1.900"
41	SR-DRAG	SPRING RETAINER, DRAG
42	NT-DRAG	JAM NUT, NYLON

Technical Support:

8:30 AM – 5:00 PM (EST)

Penske Racing Shocks – Technical Center
150 Franklin Street
Reading, PA 19602
United States

610.375.6180

Penske Racing Shocks Midwest
12666 U.S. Route 12
Brooklyn, MI 49230
United States

517.592.6681

www.penskeshocks.com



Rev. 04-05-10