



Motorcycle Shock Technical Manual

8900 Series

Main Office

150 Franklin St. • P.O. Box 1056
Reading, PA 19603

(610) 375-6180 • (610) 375-6190 Fax

Southeast

771-28 Fentress Blvd. • P.O. Box 11586
Daytona Beach, FL 32120

(386) 274-5336 • (386) 274-5442 Fax

Midwest

12666 US-12 • P.O. Box 666
Brooklyn, MI 49230

(517) 592-6681 • (517) 592-3696 Fax

Table of Contents

Page

Installation	2
Notes	3
Ride Height Adjustment	4
Adjustment Recommendations	5
8900 Series Shock	
Parts List	6
Specifications	7
8981 Series Compression Adjuster	
Parts List	8
Operational Guide	9
8986 Series Compression Adjuster	
Parts List	10
Operational Guide	11
8987 Series Compression Adjuster	
Parts List	12
Operational Guide	13
8900 Series Rebound Adjuster	14
Disassembly / Assembly Instructions	15
Suggested Maintenance	16
Trouble Shooting	16
Valving	
General Valving Characteristics	17
A Guide To Damper Tuning	18
Basic Start-up Procedure	19
Valve Stacks	20
VDP and Digressive Valving Information Options	21
VDP 55mm Linear Base Shim	21
Preload Shim Spacers	21
Pistons	
Flow Rate Through Multiple Bleed Holes	22
Piston Selection	23
Linear Piston	24
Digressive Piston	25
Velocity Dependent Piston (VDP)	26
Damping Adjustments	28
Dyno Graph Overview	30
Notes	34

Installation

Your new Penske Racing Shock comes pre-adjusted at baseline settings. However, you must check your rear sag before you race! This is very important for optimum performance.

Setting the Sag*

* BUELL APPLICATIONS: Use Buell spring sag recommendations.

STEP 1

- 1) Without a rider on the bike, have an assistant lift the rear of the motorcycle until the rear wheel is off the ground slightly.
- 2) Using a tape measure, measure the distance between the axle center line and a convenient location on the rear subframe (Figure 1).
- 3) Record this measurement as "A".

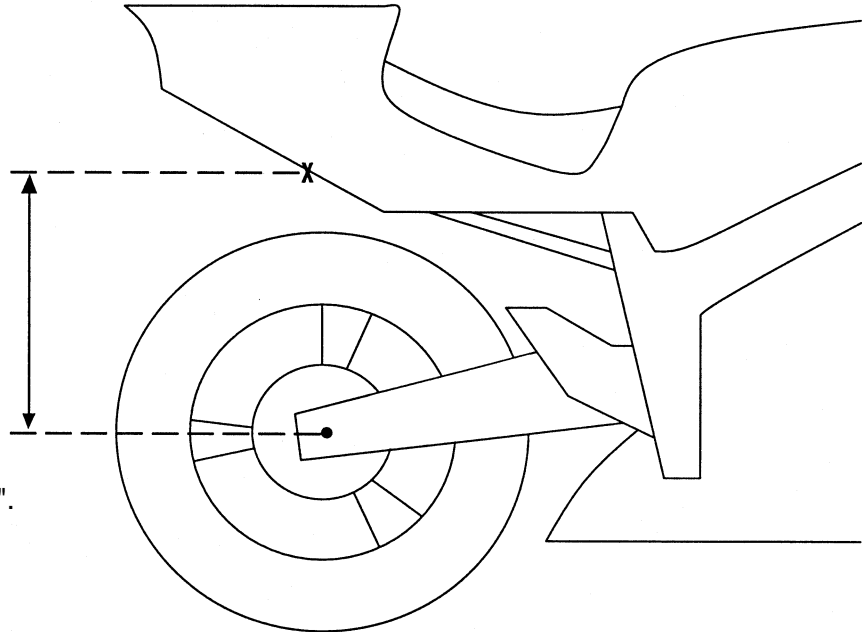

Figure 1.

STEP 2

- 1) This step requires the rider and two additional people.
- 2) One person should hold the front of the motorcycle, straddling the front tire.
- 3) Have the rider, wearing all of their gear, sit on the bike in a tuck position.
- 4) The third person should then measure the distance between the axle center line and a convenient location on the rear subframe (same locations used in Step 1).
- 5) Record this measurement as "B".

STEP 3

- 1) Subtract "B" from "A". This number is your sag.

The amount of sag required varies from rider to rider and from track to track.

The sag should be between 7/8" and 1 1/6".

If the sag is greater than 1 1/6", preload the spring by turning the adjustable spring collar.

If the sag is less than 7/8", remove preload by turning the adjustable spring collar.

Notes

Ride Height Adjustment

Adjusting Rear Ride Height

1. Loosen the jam nut with 1" wrench.
2. Adjust the eyelet length (shorter or longer). See #2 below.
3. Tighten the jam nut. See #3 below.

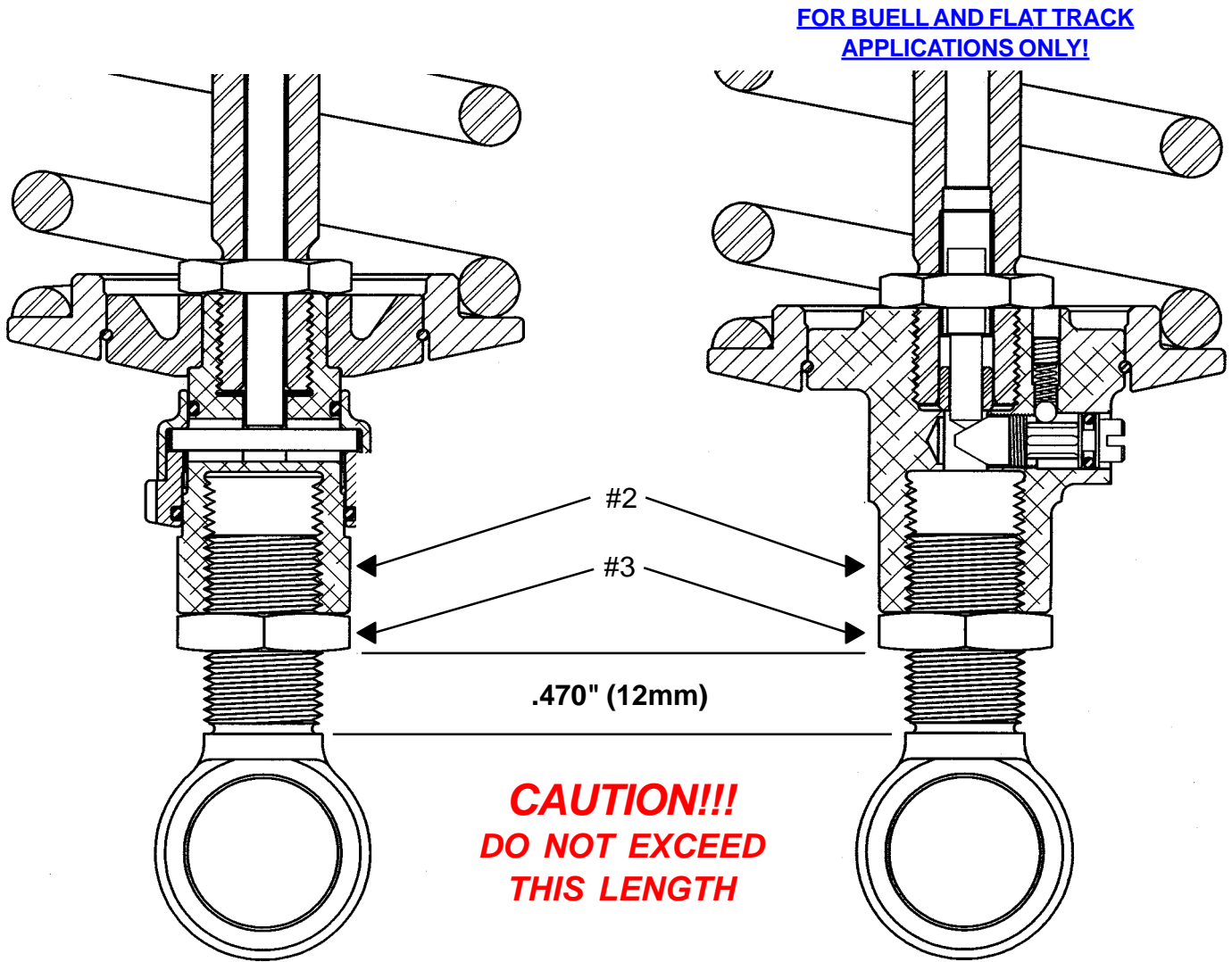

Ride Height Affects

Going **LONGER** with rear shock length "eye to eye" will:

1. Raise the rear ride height.
2. Transfer weight from the rear wheel to the front wheel.
3. Make the front turn in quicker.
4. Reduce chain torque to the rear wheel.

Going **SHORTER** with rear shock length "eye to eye" will:

1. Lower the rear ride height.
2. Transfer more weight to the rear wheel.
3. Make the front turn in slower.
4. Increase chain torque to the rear wheel.

Adjustment Recommendations

Road Race Track Tuning: Symptoms and Suggestions

- A. Change only one adjustment at a time, and send the rider out for evaluation and feedback.
- B. Take notes: Keep track of rider comments, lap times, tire conditions, and current weather conditions.
- C. Be patient, go back to your original settings if you get lost.

Symptom:

Tuning List:

Harsh over bumps:

1. Go softer with low speed compression, 2 to 4 clicks at a time (counter clockwise)
2. Go softer with high speed compression, 1 to 2 clicks at a time.
3. Increase rear spring sag, -1/2 to 1 turn at a time on spring perch.
4. Change to a softer spring rate.
5. Note: Too soft on compression can bring about a harsh feeling by allowing too much shock travel.

Excessive wheel spin exiting corners:

1. Repeat above steps.
2. Rebound can be too fast, allowing the rear to unload and spin the tire. Use caution when changing rebound.

Wallowing exiting corner:

1. Stiffen low speed compression (clockwise).
2. Stiffen high speed compression, 1 to 2 clicks at a time.
3. Decrease rear spring sag.
4. Slow down rebound, 1 to 2 clicks at a time (clockwise).
5. Change to a stiffer spring rate.

Slow turn-in:

1. Raise fork legs in triple clamps
2. Increase rear eyelet length, 1/2 to 1 turn at a time. Cannot exceed 12mm of thread exposed.
3. Soften fork compression
4. Increase front fork sag
5. Speed-up rear rebound.

Mid corner push - front:

1. Stiffen rear low speed compression
2. Slow down fork rebound

8900 Series Shock Parts List

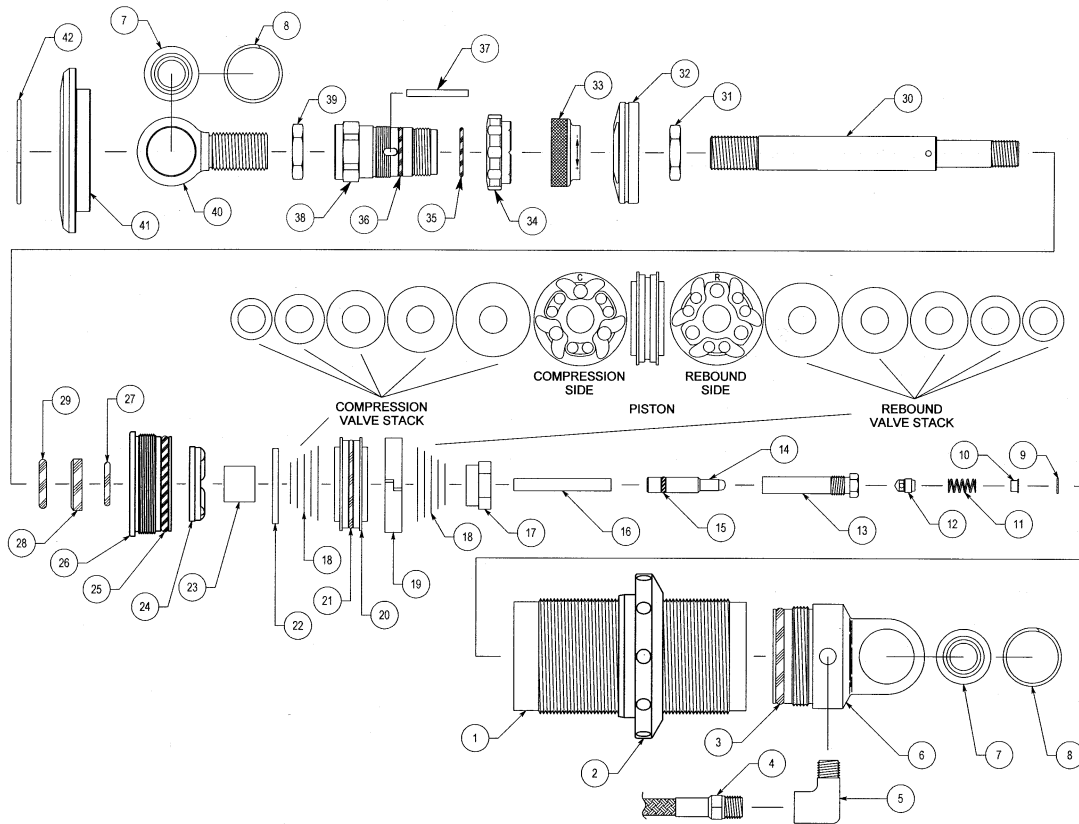

ITEM NO.	PART NO.	DESCRIPTION
1	BD-81__*	Body, Aluminum Coil-over (10.0" - 24.0")
2	RH-89225	Ride Height Adjuster, 8900, 2.25"
3	OR-2221-B	O-Ring, 2-221, Buna 70
4	HO-87__*	Hose (4" - 36" in 1" increments)
5	FT-__*	Fitting, (45° or 90°), 1/8" NPT
6	BC-81__*	Body Cap, 8100, (0°, 45°, 90°, 135°)
	BC-89CL	Body Cap, 8900 Clearance
7	MO-8T	Mono Ball, .500 ID, Teflon
	MO-8T20	Mono Ball, .500 x .875 OD
	MO-15T	Monoball, 15mm ID x 1.00 OD
8	RR-16	Retaining Ring, 1.025 Spiroloc
	RR-10	Retaining Ring, .875 Spiroloc
*	JT-76RD	Jet, Rebound Complete (Includes items 9-13)
9	RR-05	Retaining Ring, .250 Internal
10	JT-76HAT	Jet, Top Hat
11	SP-15	Spring, (FF71)
12	JT-76POP	Jet, Poppet
13	JT-RDHSNG	Jet, Rebound, Straight Thru
14	NE-76	Needle
15	OR-2007-B	O-Ring, 2-007, Buna 70
16	MR-8100	Metering Rod
17	NT-02R	Ring Nut, 1/2" - 20
18	VS-__*	Valve Stack
19	PB-55	Piston Band, 55mm
20	PI-__*	Piston
21	OR-2028-B	O-Ring, 2-028, Buna 70

ITEM NO.	PART NO.	DESCRIPTION
22	VW-99	Top Out Plate, 1.375 x .504
*	AS-89SB	Assembly, 8900 Shaft Bearing (Includes items 23-28)
23	BU-10DU06	Bushing, DU .625 x .375
24	BR-37	Bump Rubber, Top Out (Clear)
25	OR-2221-B	O-Ring, 2-221, Buna 70
26	SB-89	Shaft Bearing, 8900
27	OR-2114-V	O-Ring, 2-114, Viton 75
28	SL-09	Shaft Wiper, .625 Poly (Blue)
29	OR-2312-B	O-Ring, 2-312, Buna 70
30	SH-__**	Shaft, Adjustable, (10.0" - 24.0")
31	NT-04J	Jam Nut, 5/8" - 18
*	AS-89KBPLAT	Assembly, 8900 Knob Platform (Includes items 32-38)
32	SR-89SRM	Spring Retainer, 8900 Mount
33	CP-76RD	Cap, Rebound Adjuster
34	KN-76RD	Knob, Rebound Adjuster
35	OR-2017-B	O-Ring, 2-017, Buna 70 Duro
36	OR-2017-B	O-Ring, 2-017, Buna 70 Duro
37	DO-09	Dowel Pin, 1/8" x 1 1/8"
38	SM-89KB	Shaft Mount, 8900, Knob Platform
39	NT-06J	Jam Nut, 11/16" - 20
40	EY-89__*	Eyelet, 8900, Motorcycle Model _____
	CL-89__*	Clevis, 8900, Motorcycle Model _____ (not shown)
41	SR-89225	Spring Retainer, 8900, 2.25"
42	RR-06	Wire Ring, .0625 Wire Diameter x 1.900

NOTE: Each shock also includes (1) BR-38 Bump Rubber, 38 gr.

The following parts are in the rebound adjuster for Buell And C&J Applications Only!

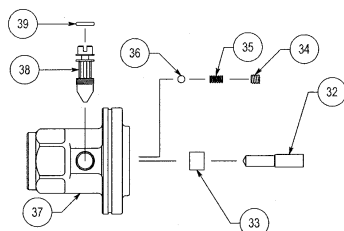

ITEM	PART NO.	DESCRIPTION
32	MR-89	Metering Rod, 8900
33	BU-04-BZ	Bushing, .200 Bronze
34	SC-08	Screw, Socket Set, 8-32 x 3/8"
35	SP-14	Spring, (A109)
36	BA-125-ST	Ball, Steel 1/8"
37	SM-89	Shaft Mount, 8900, Adj. Platform
38	RS-89	Rebound Screw, 8900/Slotted
39	OR-2009-B	O-Ring, 2-009, Buna 70 Duro

8900 Series Shock Specifications

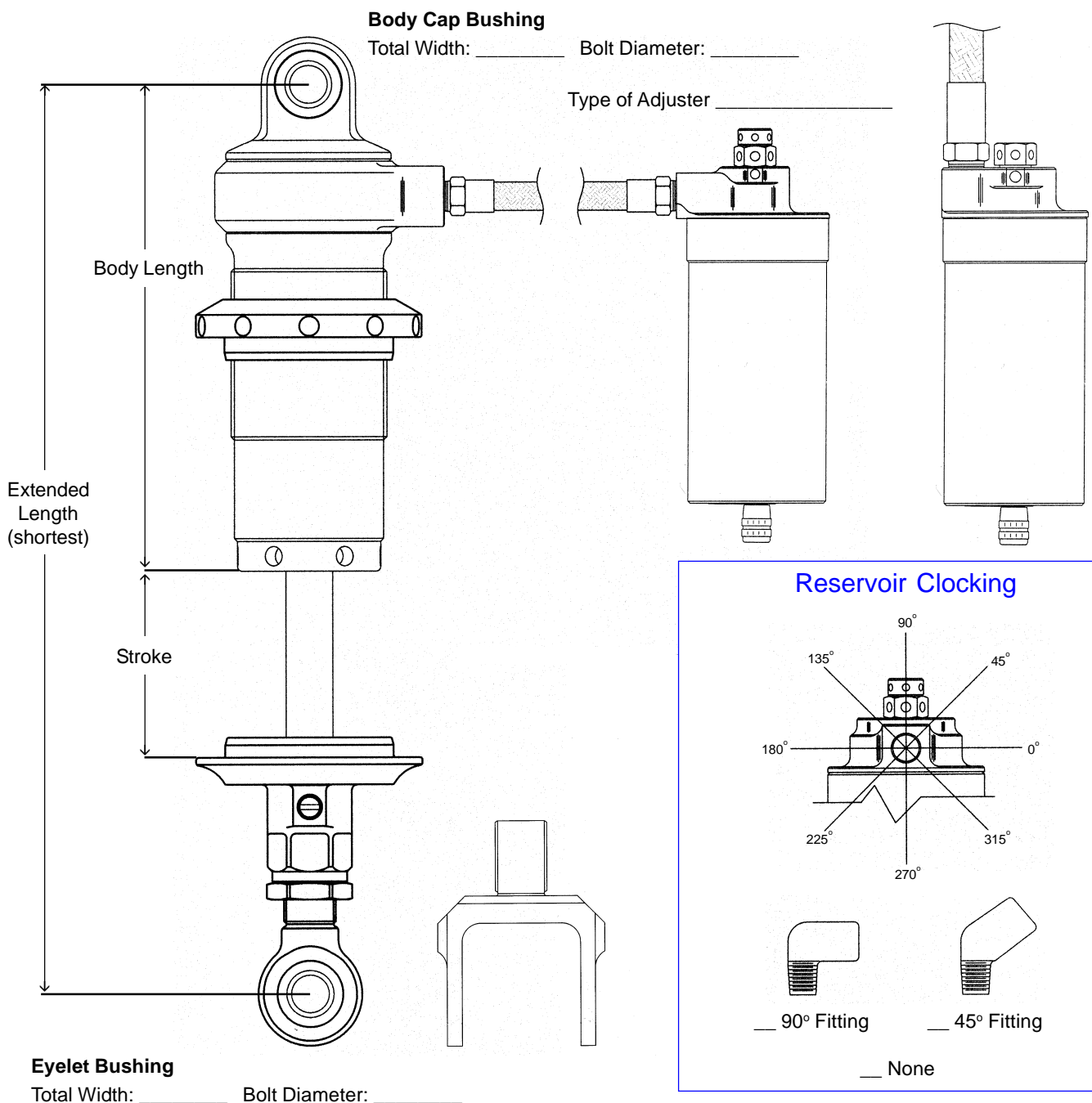
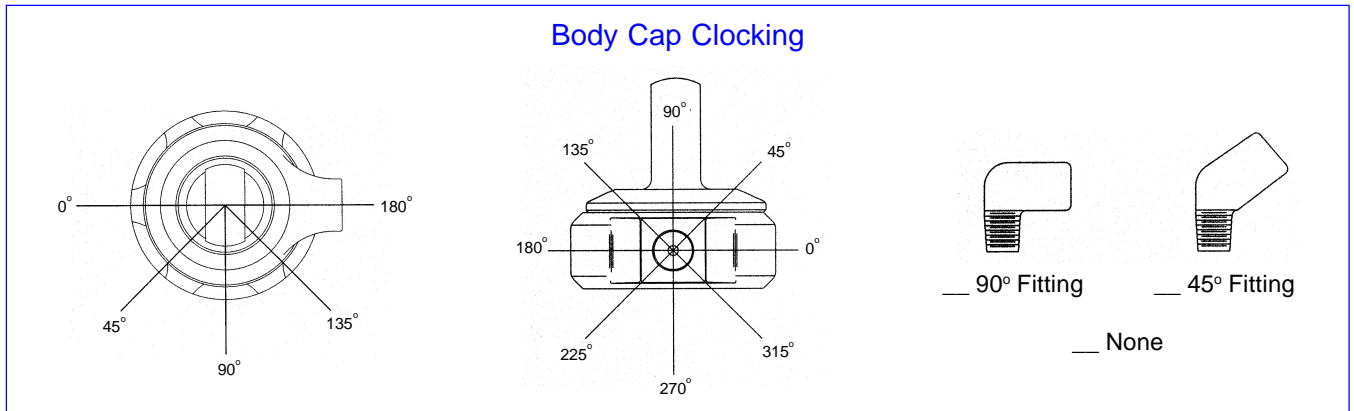

8981 Series Compression Adjuster Parts List

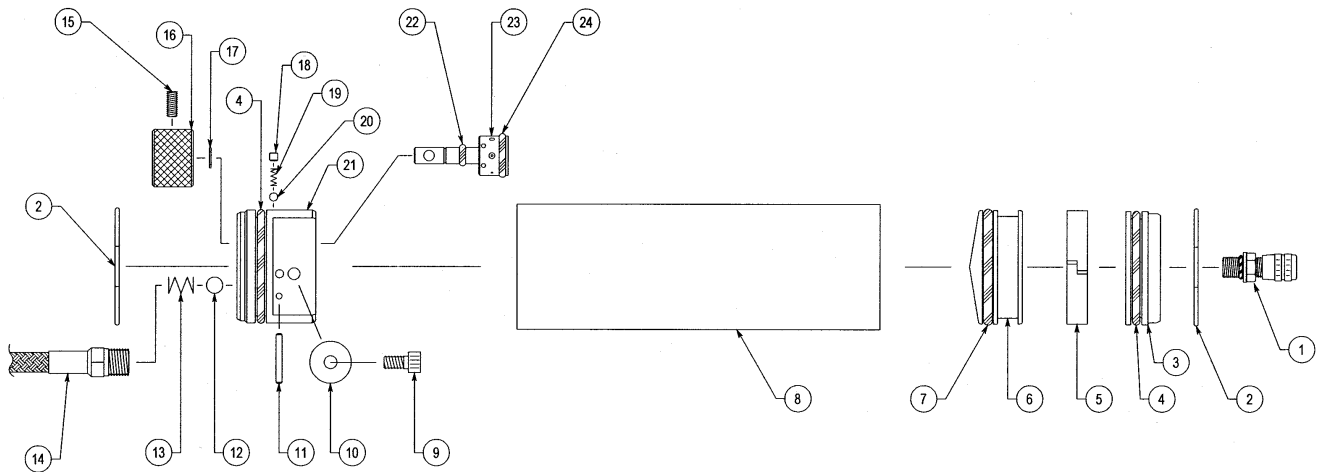

ITEM NO.	PART NO.	DESCRIPTION
		8981 Series CD Adjuster Option Available in 5.5" and 7" Body Lengths
1	IU-22-S	Air Valve, Port O-Ring, Steel
	IU-04	Valve Core, 2000 psi
	IU-06	Valve Cap, High Temperature
	OR-2010	O-Ring, 2-010, Buna 70
2	RR-06	Wire Ring, .0625 Wire Diameter x 1.900
3	CP-81R	Cap, 8100 Reservoir
4	OR-2221-B	O-Ring, 2-221, Buna 70
5	PB-55	Piston Band, 55mm
6	PI-81R	Piston, Reservoir 1.72 Diameter
7	OR-2323-M	O-Ring, 2-323, Moly 70
8	RB-81__*	Reservoir Body, 8100, (5.50" or 7.00")
9	SC-24	Screw, SHCS, 10-24 x 3/8"
10	VW-03	Washer, Valve, .635 x .015 x .191
11	DO-04	Dowel Pin, 3/32" x 3/4"

ITEM NO.	PART NO.	DESCRIPTION
12	BA-250-ST	Ball, Steel - 1/4"
13	SP-10	Spring, (TA2086)
14	HO-87__*	Hose (4" - 36" in 1" increments)
	AS-81UD	Assembly, Update 8100 CD Adj with Knob (Includes Items 4, 9-13, 15-24)
15	SC-02	Screw, Socket Set, 8/32" x 3/8"
16	KN-81	Knob, CD 8100
17	RR-02	Retaining Ring, .250 External
18	SC-08	Screw, Socket Set, 8-32 x 1/8"
19	SP-14	Spring, (A109)
20	BA-125-ST	Ball, Steel - 1/8"
21	HG-81D	Housing, CD 8100 Dished
22	OR-2006-B	O-Ring, 2-006, Buna 70
23	DR-81	Drum, CD 8100
24	OR-2013-B	O-Ring, 2-013, Buna 70

* Incomplete Part Number

8981 Series Compression Adjuster

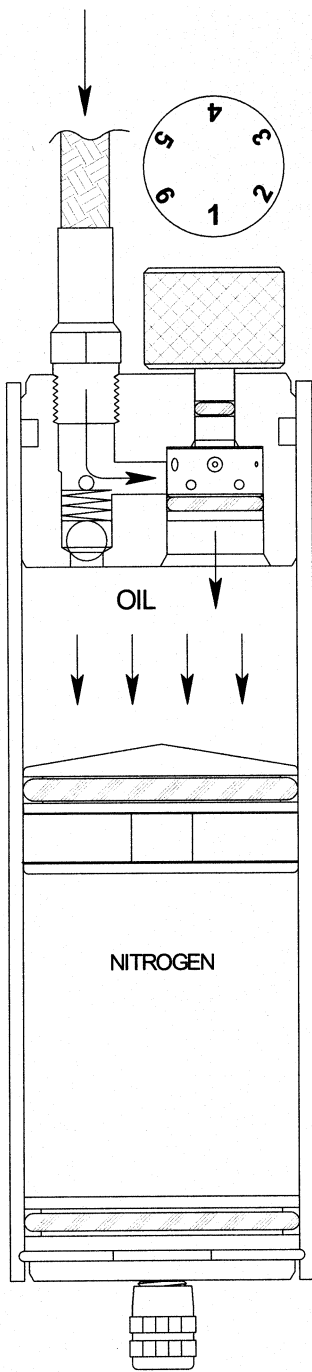

Figure 1

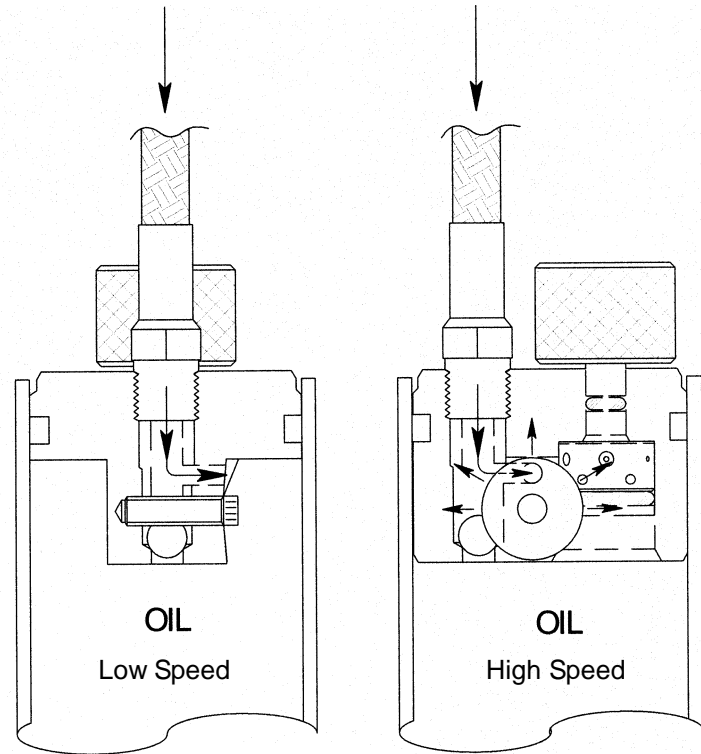

Figure 2

The 8981 compression adjuster is located in the remote reservoir assembly. The remote reservoir serves as an extension of the shock absorbers vital elements: oil and nitrogen. The remote reservoir theory allows for the use of increased volumes of oil and nitrogen while allowing for smaller shock packaging. Increased nitrogen volume is essential for consistent damping forces throughout a long race and extreme conditions.

In the compression mode of the shock absorber, fluid is forced into the remote reservoir in direct proportion to the area of the shaft entering the shock body. As fluid enters the reservoir, it must pass through the compression adjuster. Inside the compression adjuster is the CD drum. The CD drum has (6) settings, numbered (1-6), with number one setting (the largest hole) being full soft and number six (the smallest hole) being full firm. As fluid is forced through the CD drum (Figure 1), it is metered through one of the preassigned orifices in the drum; it then enters the reservoir body, moving the floating piston. The floating piston is designed to separate the fluid and nitrogen, eliminating any chance of aeration.

In the event of high speed shaft velocities, fluid passing through the hole in the CD drum could pack-up, causing an increase in damping forces, due to the fact that fluid can no longer pass through the hole. In this event, the fluid forces open the blow-off valve (Figure 2). The blow-off valve makes a more linear damping curve.

Note: The remote compression adjuster is a fine tuning device for the main valving located inside the shock absorber.

8986 Series Compression Adjuster Parts List

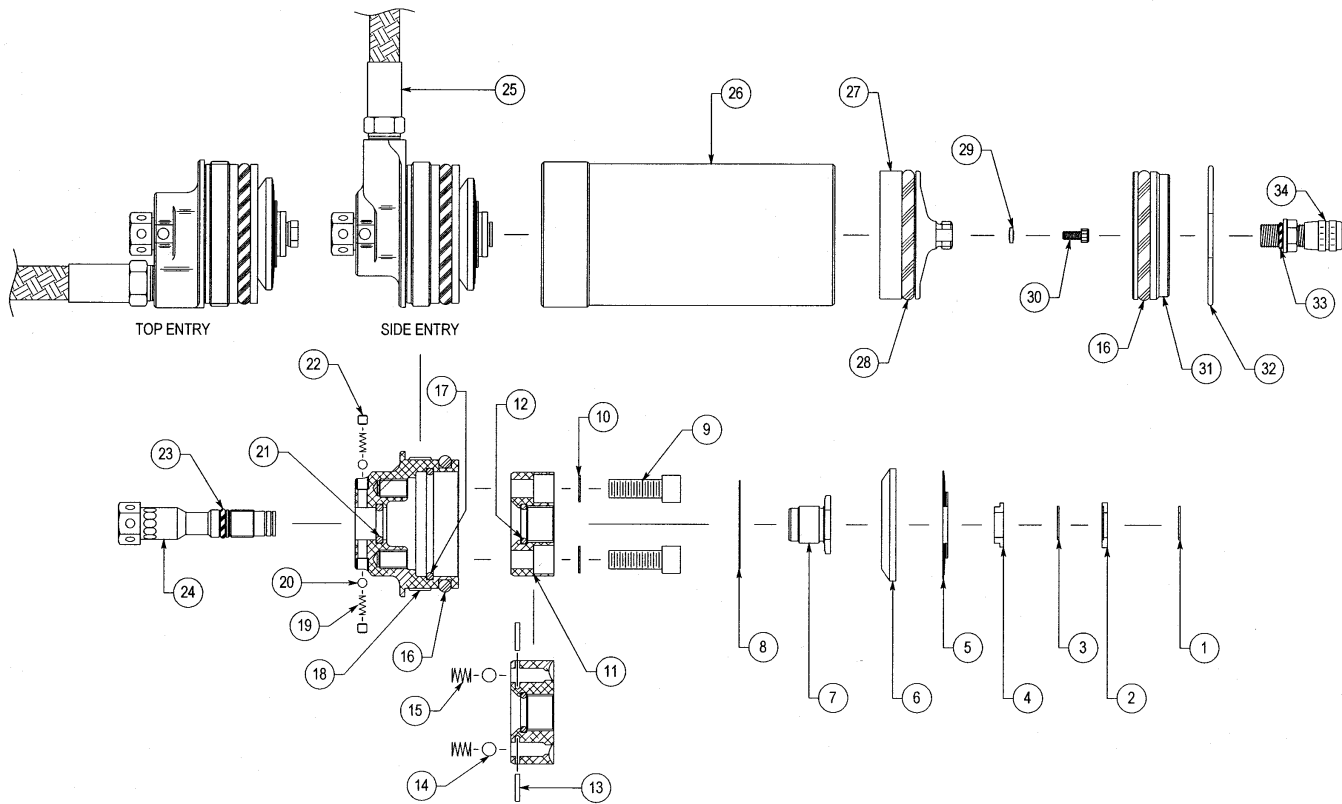

ITEM NO.	PART NO.	DESCRIPTION
		8986 Series Adjuster Option Available in 4", 5", and 6" Body Lengths
1	RR-12	Retaining Ring, .343 External
2	CA-92	Cage, CD Clasp .343 Diameter
3	RR-12	Retaining Ring, .343 External
4	CA-90	Cage, CD Top Hat .343 Diameter
5	VW-91	Washer, Valve, 1.475 x .010
	VW-88	Washer, Valve, 1.350 x .008
	VW-66	Washer, Valve, 1.200 x .006
	VW-44	Washer, Valve, 1.050 x .004
	VW-28	Washer, Valve, .900 x .008
	VW-30	Washer, Valve, .900 x .010
	VW-38	Washer, Valve, .900 x .020
6	CA-76CD	Cage, Compression Adjuster
7	SC-76INS	Screw, Piston Insert
8	VW-70	Washer, Valve, 1.200 x .010
9	SC-06	Screw, SHCS, 1/4" -20 x 3/4"
10	VW-01-C	Crush Washer, .25 ID, Copper
11	PI-76CD	Piston, Compression Adjuster
12	OR-2013-B	O-Ring, 2-013, Buna 70
13	DO-06	Dowel Pin, 1/16" x 3/8"
14	BA-187-ST	Ball, Steel - 3/16"

ITEM NO.	PART NO.	DESCRIPTION
15	SP-16	Spring, (1460)
16	OR-2222-B	O-Ring, 2-222, Buna 70
17	OR-2028-B	O-Ring, 2-028, Buna 70
18	HG-76___*	Housing, 8760, (Side Entry or Top Entry)
19	SP-14	Spring, (A109)
20	BA-125-ST	Ball, Steel - 1/8"
21	OR-2013-B	O-Ring, 2-013, Buna 70
22	SC-08	Screw, Socket Set, 8/32" x 1/8"
23	OR-2010-B	O-Ring, 2-010, Buna 70
24	SH-86CD	Shaft, CD High Speed
25	HO-87___*	Hose (4" - 36" in 1" increments)
26	RB-76___*	Reservoir Body, 8760, (4.00", 5.00" or 6.00")
27	PI-76	Piston, Floating 1.75 Diameter
28	OR-4222-B	Quad Ring, 4-222, Buna 70
29	SL-87	Seal, Dowty
30	SC-18	Screw, SHCS, 4 - 40 x 1/4"
31	CP-76	Cap, Reservoir Port O-Ring
32	RR-06	Wire Ring, .0625 Wire Diameter x 1.900
33	OR-2010-B	O-Ring, 2-010, Buna 70
34	IU-20-A	Air Valve, Port O-Ring, Aluminum
	IU-04	Valve Core, 2000 psi
	IU-06	Valve Cap, High Temperature

* Incomplete Part Number

8986 Series Compression Adjuster

Fixed Low Speed Bleed Circuit

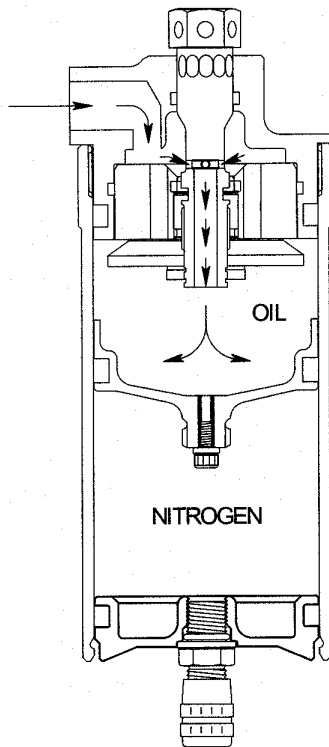

High Speed Flow Circuit

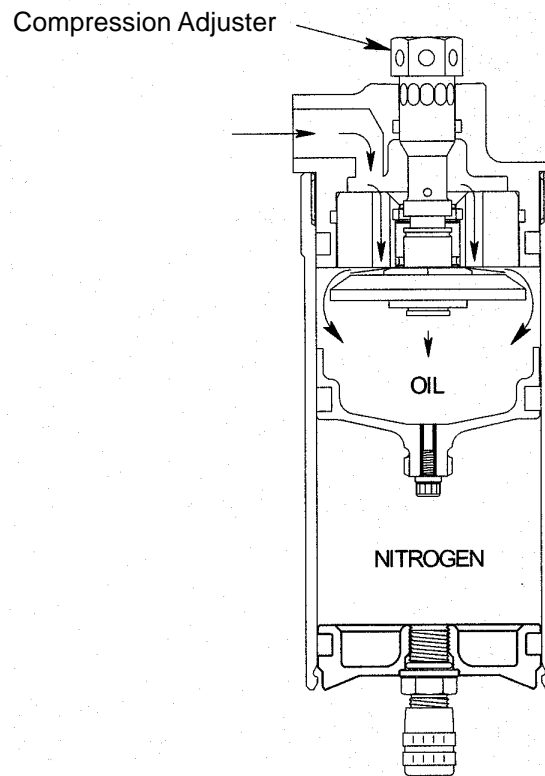

COMPRESSION ADJUSTMENT

In the state of low shaft velocities (i.e. corner entry, exit, and power down), oil is displaced within the damper in direct proportion to the volume of the shaft entering the body. The displaced fluid passes through the compression adjuster where it is metered through a fixed, low speed bleed orifice. Due to the small diameter of this orifice and the viscosity of the damper fluid, a pressure loss occurs across the orifice. This loss of pressure is a loss of energy in the fluid due to friction and the subsequent opposing damping force is generated.

As the shaft velocities increase, the same amount of fluid must pass through the low speed bleed orifice, but at a much higher rate. The viscosity of the fluid causes a greater resistance to flow at the orifice entrance which in turn produces a large internal force on the CD housing. The other major internal components, namely the piston and shim cage, are designed to handle this extra force by allowing the shims to “blow off” proportionally to the extra force generated, much like a coil spring compresses proportionally to the axial load applied. With this arrangement, the low speed bleed orifice still meters fluid during high speed shaft movements, but the extra forces generated are handled with the shims which have less resistance to flow at higher velocities. They are designed to virtually bypass the low speed orifice and form a new fluid circuit. The force at which this occurs can be varied by turning the compression adjuster in or out, which preloads the shims. Therefore, as the preload on the shims increases, the static force required for them to activate is increased as well. The name designation for the parts also clue one in to their purpose, with the low speed bleed orifice handling low velocity bleed flows and the piston/shim arrangement handling high velocity flows. This principle originated in the main shaft piston/shim arrangement and follows similar behavior.

NOTE: When making adjustments, use the **full soft** setting (adjuster wound all the way in against the reservoir body) as a starting point when counting the number of “clicks” to the desired setting. The full soft setting should correspond to a clicker number designation of **0**. This starting datum has been proven to be most reliable and repeatable when making compression adjustments. There are 22 +/- clicks of adjustment.

8987 Series Compression Adjuster Parts List

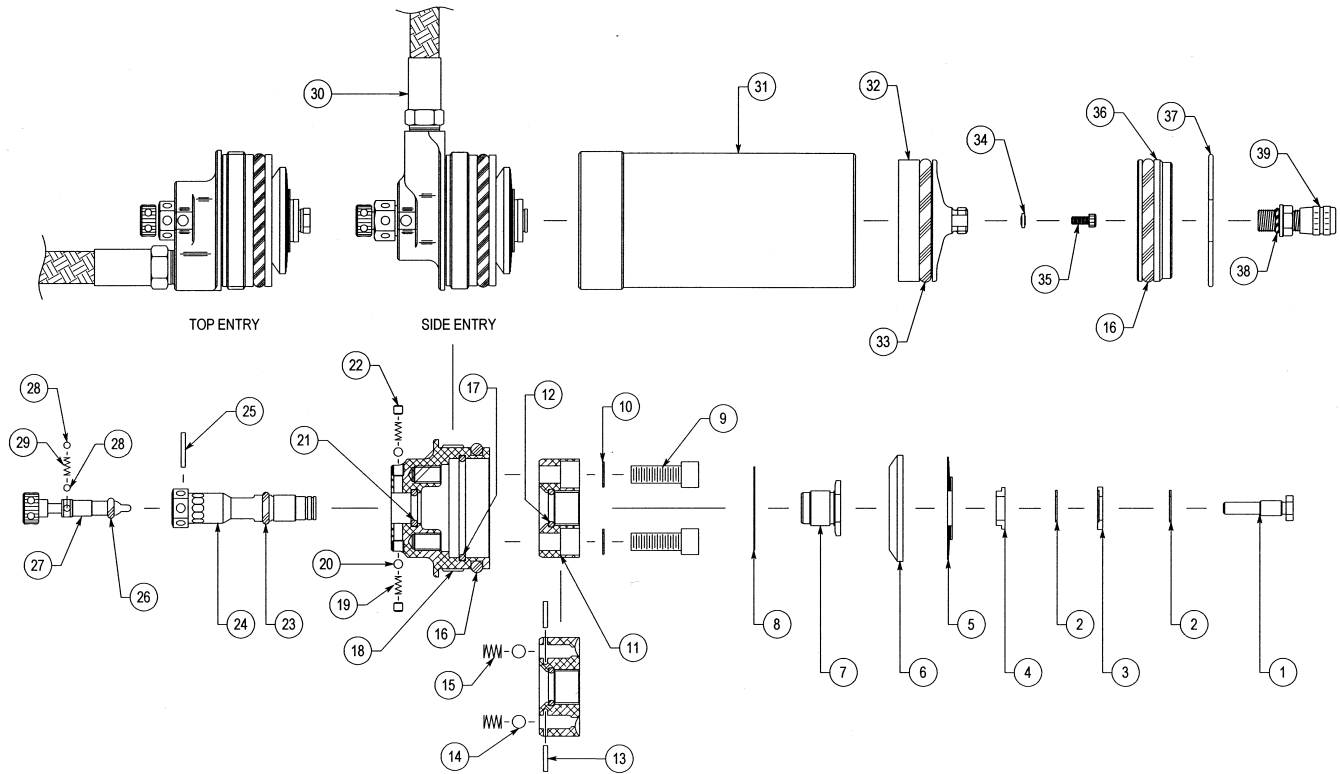

ITEM NO.	PART NO.	DESCRIPTION
8987 Series Adjuster Option Available in 4", 5", and 6" Body Lengths		
1	JT-76CDSH	Jet, High Speed Shaft
2	RR-12	Retaining Ring, .343 External
3	CA-92	Cage, CD Clasp .343 Diameter
4	CA-90	Cage, CD Top Hat .343 Diameter
5	VW-91	Washer, Valve, 1.475 x .010
	VW-88	Washer, Valve, 1.350 x .008
	VW-66	Washer, Valve, 1.200 x .006
	VW-44	Washer, Valve, 1.050 x .004
	VW-28	Washer, Valve, .900 x .008
	VW-30	Washer, Valve, .900 x .010
	VW-38	Washer, Valve, .900 x .020
6	CA-76CD	Cage, Compression Adjuster
7	SC-76INS	Screw, Piston Insert
8	VW-70	Washer, Valve, 1.200 x .010
9	SC-06	Screw, SHCS, 1/4" -20 x 3/4"
10	VW-01-C	Crush Washer, .25 ID, Copper
11	PI-76CD	Piston, Compression Adjuster
12	OR-2013-B	O-Ring, 2-013, Buna 70
13	DO-06	Dowel Pin, 1/16" x 3/8"
14	BA-187-ST	Ball, Steel - 3/16"
15	SP-16	Spring, (1460)
16	OR-2222-B	O-Ring, 2-222, Buna 70
17	OR-2028-B	O-Ring, 2-028, Buna 70

ITEM NO.	PART NO.	DESCRIPTION
18	HG-76___*	Housing, 8760, (Side Entry or Top Entry)
19	SP-14	Spring, (A109)
20	BA-125-ST	Ball, Steel - 1/8"
21	OR-2013-B	O-Ring, 2-013, Buna 70
22	SC-08	Screw, Socket Set, 8/32" x 1/8"
23	OR-2010-B	O-Ring, 2-010, Buna 70
24	SH-76CD12	Shaft, CD High Speed 12pt
25	DO-18	Roll Pin, 1/16" x 1/2"
26	OR-2004-B	O-Ring, 2-004, Buna 70
27	SC-76CDLS	Screw, CD Low Speed
28	BA-093-ST	Ball, Steel - 3/32"
29	SP-12	Spring, (3648)
30	HO-87___*	Hose (4" - 36", in 1" increments)
31	RB-76___*	Reservoir Body, 8760, (4.00", 5.00", or 6.00")
32	PI-76	Piston, Floating 1.75 Diameter
33	OR-4222-B	Quad Ring, 4-222, Buna 70
34	SL-87	Seal, Dowty
35	SC-18	Screw, SHCS, 4 - 40 x 1/4"
36	CP-76	Cap, Reservoir Port O-Ring
37	RR-06	Wire Ring, .0625 Wire Diameter x 1.900
38	OR-2010-B	O-Ring, 2-010, Buna 70
39	IU-20-A	Air Valve, Port O-Ring, Aluminum
	IU-04	Valve Core, 2000 psi
	IU-06	Valve Cap, High Temperature

* Incomplete Part Number

8987 Series Compression Adjuster

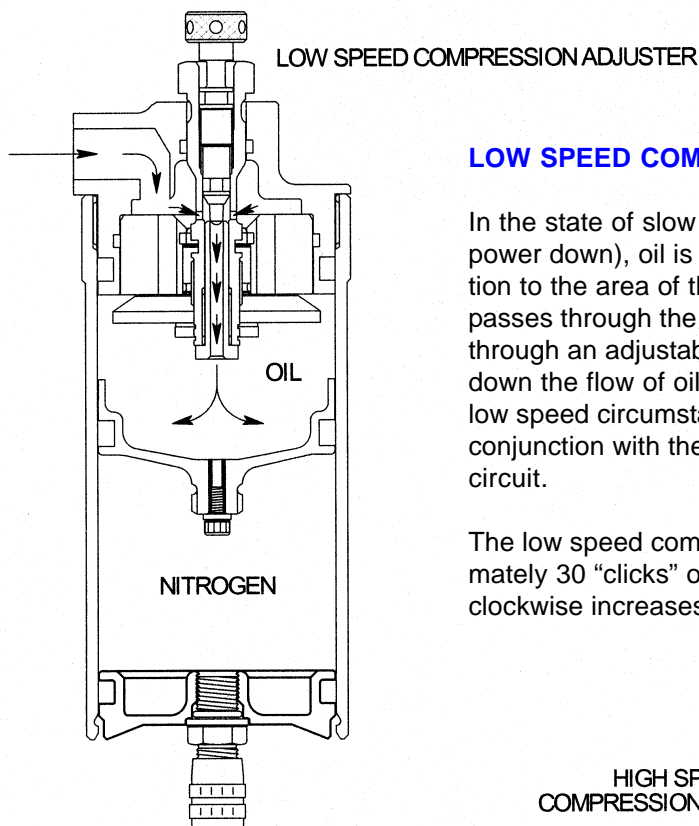

LOW SPEED COMPRESSION ADJUSTMENT

In the state of slow shaft movement (i.e., corner entry, exit, and power down), oil is displaced into the reservoir in direct proportion to the area of the shaft entering the shock body. The oil passes through the compression adjuster where it is metered through an adjustable needle and jet assembly. By shutting down the flow of oil, the oil is restricted, causing a stiffer feel in low speed circumstances. The low speed adjuster works in conjunction with the high speed adjuster to delay the high speed circuit.

The low speed compression bleed bypass adjuster has approximately 30 "clicks" of adjustment. Turning the adjuster knob clockwise increases the low speed damping.

HIGH SPEED COMPRESSION ADJUSTER

HIGH SPEED COMPRESSION ADJUSTMENT

In fast shaft movement (i.e. bumps, track inconsistencies, etc.), oil is displaced into the reservoir, as in the low speed state, but at a much faster velocity. The oil is forced to bypass the low speed needle and jet due to the fact that the small orifice in the jet causes the oil to hydraulic. In turn, the oil is forced through another piston in which its orifices are covered by another shim stack. This shim stack is preloaded with force from the CD cage and preload shims. By turning the high speed adjuster clockwise (stiffer), you are preloading the CD cage and shims, making it tougher for the oil to flex the shims.

The operation of the high speed adjuster assembly effect is timed by the adjustment of the low speed needle and shaft velocity. (i.e., if the low speed needle is full soft, at high speed a larger volume of oil will initially pass through the low speed jet slightly delaying the operation of the high speed bypass mode.)

Turning the black hex adjuster clockwise increases the high speed damping. There are 18 clicks of high speed adjustment counting from full soft.

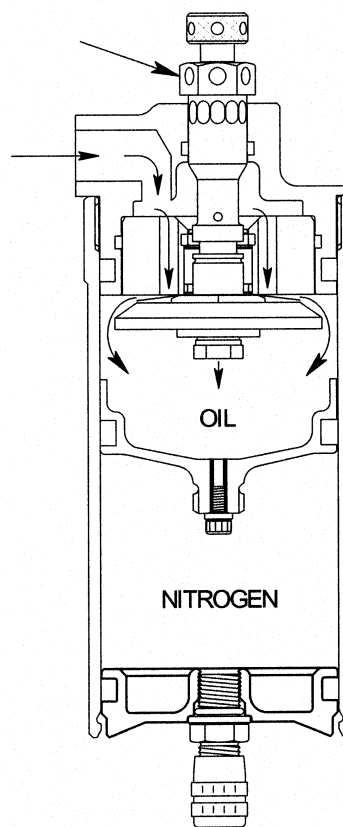

NOTE: When making adjustments on the high speed adjuster, start at the full soft setting (adjuster wound all the way in against the reservoir body) counting the clicks toward full firm. When adjusting low speed, start at the full firm setting (adjuster wound all the way in against high speed adjuster) counting the clicks toward full soft. This makes your settings more precise and less confusing for your records.

8900 Series Rebound Adjuster

8760 Needle and Jet

The 8760 jet and needle combination have been designed to give the user a broader and more linear range of adjustment for bleed past the piston on rebound.

The 8760 jet utilizes a spring loaded poppet valve to check the flow. This gives a better seal against the flow and a quicker response time as the shaft changes direction.

This needle has a curved parabolic tip, which gives a very fine, linear adjustment in damping across the entire range provided by the jet.

The 8760 needle and jet will fit any of our adjustable shafts, but they must be used together and cannot be interchanged with older style needles and jets.

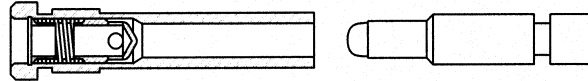

When installing any jet, apply a tiny drop of blue Loctite™ to the threads and torque to 120 in•lbs.

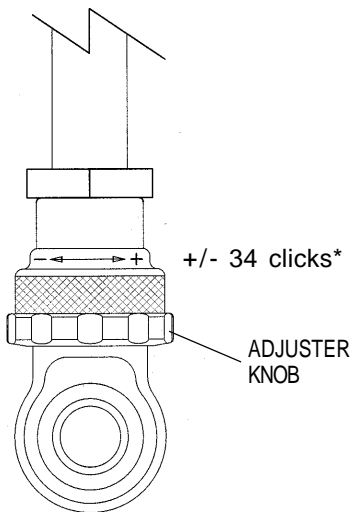

The adjuster (red knob) is located at the base of the adjustable platform. During the compression or rebound stage of the shock movement, fluid is forced through two ports in the main shaft. Inside the main shaft is a needle and jet assembly, which adjusts the amount of fluid passing through the jet. By turning in the adjuster (clockwise), the needle is forced up into the jet, restricting the fluid, causing firmer damping forces. In reverse, by turning the adjuster out (counter clock-wise), more oil is allowed to pass through the jet causing lighter damping forces. The adjustment assembly, is a timed control for the shims located on the main piston to work.

*
+ = More Damping
- = Less Damping

FOR BUELL AND FLAT TRACK APPLICATIONS ONLY!!

The rebound adjuster screw on the 8900 Series shock absorber is located in the adjustable platform at the base of the main shaft.

The rebound adjuster has 25 to 30 clicks of adjustment. Note: the external rebound adjustment is only a fine tuning device for the main valving located inside the shock absorber.

During the rebound (extension) stage of the shaft movement, fluid flows through two ports in the main shaft. Inside the main shaft is a needle and jet assembly which adjusts the amount of fluid passing through the ports. By turning in the rebound adjuster (clockwise), the needle is moved into the jet, restricting the flow, causing firmer rebound damping forces. In reverse, by turning the adjuster out (counter clockwise), more oil is allowed to pass through the ports causing lighter rebound damping forces. This rebound adjustment assembly, is in fact a timed control for the rebound shims located on the main piston.

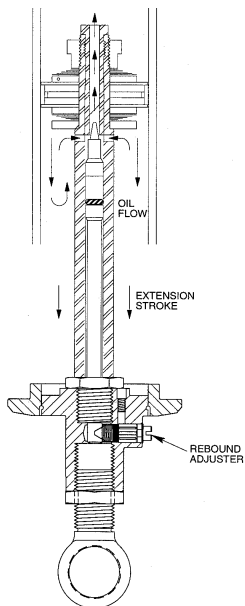

Disassembly / Assembly Instructions

Disassembly Instructions

1. Back the rebound adjuster to full soft and **depressurize** the remote reservoir.
2. Clamp the body cap eyelet in a vise* with the shaft pointing up. *Soft jaw vise is recommended
3. Unscrew the shaft bearing assembly and remove the shaft assembly.
4. Drain the oil. (Please dispose of properly)
5. Push the reservoir end cap up into the reservoir body. (For the 8100 Series, you must hold the hose)
6. Using a scribe, pry the wire retaining ring out of the reservoir body and remove the reservoir end cap.
7. Looking into the reservoir, you will see a threaded hole in the reservoir floating piston. Using an 8-32 (8100) or 3-8 x 24 (8760) threaded rod, remove the floating piston by holding onto the reservoir body and pulling on the threaded rod. Drain the oil from the reservoir
8. Use solvent to clean all parts, then dry and inspect them. **NOTE:** Brake cleaner use is discouraged due to the possible damaging effects on seals and wipers.
9. Inspect and replace the o-rings as needed.
10. If needed, revalving is done at this point. Clamp the adjustable platform in the vise with the piston pointing up. Remove the 1/2" ring nut from the top of the shaft assembly to access valving or to change the seals in the shaft bearing.

Assembly Instructions

1. Reassemble the shaft and piston assembly. Before installing the ring nut, there should be no more than .150" shaft to bottom threads exposed to avoid damaging the nut or shaft threads. Be sure to add sufficient constants to be able to properly torque the ring nut to 25 ft•lbs (300 in•lbs). [Use constants on CD side for linear pistons. Digressive and VDP can be varied.]
2. If the jet was removed, add a tiny drop of blue Loctite™ to its threads and torque to 120 in•lbs (maximum).
3. Torque the jam nut on shaft to 40 ft•lbs (480 in•lbs).
4. With the shock returned to the vise, fill the remote reservoir half full with oil.
5. Hold the remote reservoir above the shock body and look into shock body. When the oil level is above the fitting port, fill the reservoir to the top with oil. [8100 set CD on full hard, #6; 8660 set CD on full soft, turn knob counter clockwise until it stops against CD body; 8760 high speed CD adjuster (black hex) set on full soft, turn counter clockwise until it stops against CD body, low speed CD adjuster (silver knob) set on full hard, turn knob clockwise until it stops against high speed hex.]
6. Before the oil lowers, insert the floating piston and 8100 piston band or 8700/8760 quad ring* into the reservoir body. *Make sure the quad ring is not twisted.
7. Hold the remote reservoir below the level of the shock with the hose pointing up allowing any trapped air to flow up into the shock body. Using the handle of a mallet, push the floating piston up into the reservoir body until bottomed. [8100 CD set on full soft, #1; 8660 CD set on full soft, turn the knob counter-clockwise until it stops; 8760 high speed CD adjuster (black hex) set on full soft, turn counter-clockwise until it stops, low speed adjuster (silver knob) set on full soft, turn the knob counter-clockwise until it stops.]
8. Slowly pull the reservoir floating piston back, then push in 2 to 3 inches.
9. Repeat step #7 & #8 until there are no air bubbles seen coming from the reservoir. (When no air bubbles are seen go directly from step #7 to step #10).
10. Replace the reservoir end cap and snap ring.
11. Pressurize the remote reservoir to reposition the floating piston (approx. 150 psi).
12. Fill the shock body with oil to the bottom of the threads (1/2" from the top of the body).
13. Insert the piston/shaft assembly with the teflon piston band into the shock body, pushing the piston just below the surface of the oil, until the 2 shaft bleed hole ports are covered.
14. It is very important to remove as much air as possible from the piston assembly. To do this, start by moving the shaft up slowly and pushing down a few times using a 1" - 2" stroke, being sure to keep the two ports in the shaft below the surface of the oil, or air will be sucked back into the piston assembly. Lightly tap the eyelet a few times with a mallet to assure that all the air is released from the piston. **NOTE: this step is very important; take your time, repeat as needed.**
15. Slowly pull up on the shaft assembly until the two ports are just below the surface of the oil. Top off with oil to fill the shock body.
16. Slide the shaft bearing down without moving the shaft until the o-ring contacts the body. Depressurize the remote reservoir, tighten the shaft bearing. Do not overtighten the shaft bearing.
17. Pressurize the shock to approximately 150 psi. Please call if you have any questions on specific pressures.

NOTES

- 1) IMPORTANT: Reservoir floating piston must be repositioned before the shaft is inserted into the shock body (refer to step #11).
- 2) Penske Suspension Fluid (Silkolene Pro RSF 5 wt.) is recommended. Use of alternate fluids may have an adverse effect the damper's internal sealing components. (i.e., o-rings)

Suggested Maintenance

PRE RACE	Inspect for oil leakage. Check the nitrogen pressure.
EVERY 30 HOURS OF TRACK TIME OR YEARLY	Change oil. Replace the shaft seal o-ring, wiper, shaft bearing o-ring, reservoir cap o-ring and piston o-ring, floating piston quad ring, valve shims.

Trouble Shooting

LOSS OF NITROGEN PRESSURE	Valve core is not tight or needs replacing, o-ring on air valve needs replacing, reservoir cap o-ring needs replacing, leaking quad ring, or dowty seal.
OIL LEAK AROUND SHAFT	Shaft seal o-ring or wiper needs replacing. <u>Note: minimal oil seepage is normal.</u>
OIL LEAK AT RESERVOIR	Teflon tape seal on hose needs replacing, reservoir cap or CD housing o-ring needs replacing.
OIL LEAK BETWEEN SHAFT BEARING AND BODY	Shaft bearing o-ring needs replacing.
SHAFT WILL NOT FULLY EXTEND	Check for bent shaft, low nitrogen pressure. <i>Note: do not spray brake cleaner or solvent on the shaft wiper, it may cause it to swell and prevent proper movement.</i>

General Valving Characteristics

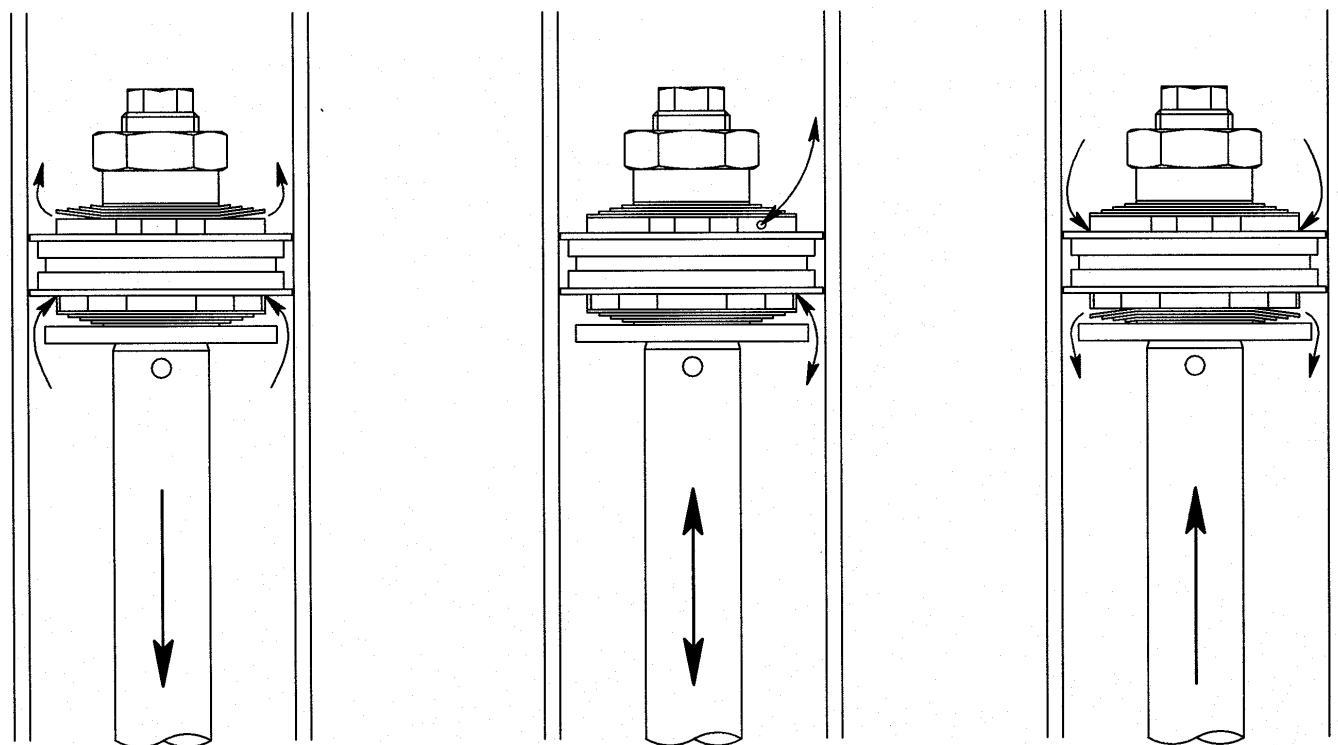

**High Speed
Rebound**

**Low Speed*
Compression and Rebound**

**High Speed
Compression**

The damping characteristics of your shock are determined by the compression and rebound valve stacks located on the main piston.

The valve stacks are made up of a series of high quality shims, which are made to flex under the force of oil flowing through the piston ports and then return to their original state.

The thickness of the individual shims determines the amount of damping force the shock will produce. By changing the thickness of the individual shims, damping forces will be altered. For example, if you are running an "A" compression valving, where all the shims in the stack are .006 thick and you replace them with a "B" compression valving, which consists of all .008 thick shims, the compression damping will increase.

* When the shaft is moving very slowly oil passes through the bleed hole, if there is one, before it passes to the shims.

A Guide To Damper Tuning

The ultimate purpose of a shock is to work together with the spring to keep the tire on the track. In compression (bump) to help control the movement of the wheel and in rebound to help absorb the stored energy of the compressed spring.

Usually in rain or low grip situations allowing more bleed or less low speed damping is desirable to delay tire loading upon initial roll.

In dry high grip conditions adding damping or restricting bleed will load the tire sooner upon initial roll increasing platform stability.

A motorcycle with too much low speed damping will usually lack grip in change of directions, cannot put power down in slower corners (wheel spin) and lack overall grip after initial turn in.

If traction is a problem coming off slow corners, reducing low speed damping or adding more bleed will help weight transfer at the rear thus increasing traction.

One of the most important things to know about these adjusters is their relative position to one another. If for instance you have the low speed set at 25 to 30 clicks (soft), the range of high speed adjustment will be lessened. Or in the opposite direction, if the high speed is set at 0 to 1 (off soft), the low speed adjustment range will be lessened.

Also, when making a big adjustment in high or low speed, the change will affect the other in a small percentage. As an example, the high speed is set at (+4) and the low speed at (-6). Now you want to set the low speed to (-2), this will also increase a percentage of the high speed force figure. By dropping the high speed from (+4) to (+3) would compensate for this low speed change so the overall “damper curve” would remain intact. The more experience you have with these the easier it will become to recognize what changes can occur in relation to different valvings. The tendency of these circuits to “cross talk” is greatly reduced in our new digressive CD piston.

The rebound adjuster consists of a needle metering flow across a hole. This metered flow bypasses the main piston/shim assembly until flow is choked off. The shims then modulate the flow.

Depending on valving, there will be an affect on adjustment range. The softer the valving (A - B), the less force range it will have. This is due to a lower pressure required to blow the valves on the main piston. Obviously the heavier the valving (C - E), the more effective the bleed becomes. On digressive pistons, pre-load also affects the range of adjustment.

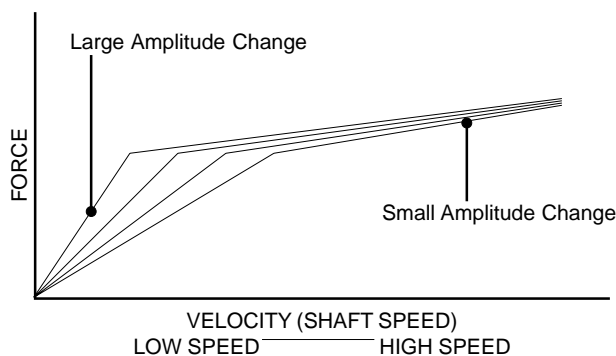

LOW SPEED ADJUSTMENT EXAMPLE

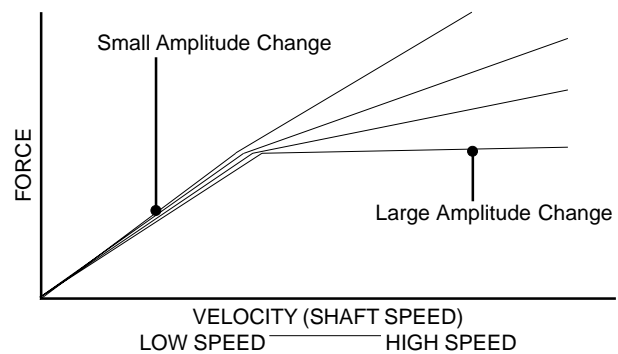

HIGH SPEED ADJUSTMENT EXAMPLE

A Guide To Damper Tuning

Also, the amount of rebound can have a great influence on weight transfer. Less front rebound allows weight transfer to the rear under acceleration. Less rebound in the rear allows for a greater amount of weight transfer to the front under braking and turn in.

When a motorcycle is over damped in rebound it can pack down in a series of bumps and a driver will recognize this as too stiff and usually will think it is compression damping. Too much rebound can cause lack of grip on cornering.

When making a large spring change keep in mind where the rebound adjuster is and do you have enough range to compensate. Sometimes a spring change will bring a better balance to the damping values after the spring change. If the spring/shock combination was balanced, the rule of thumb is a stiffer spring requires lower compression and higher rebound. A softer spring requires higher compression and lower rebound.

Basic Start-up Procedure

The following setup procedures are basic recommendations for reaching an initial starting point using double adjustable Penske Racing Shocks. This procedure is ideal for use on an open test schedule. A race weekend may not allow enough time. Start by making the compression adjustments as described below, until it feels right, then move to the rebound adjustments.

COMPRESSION

The idea is to set the compression damping forces to suit the bumps in critical areas, such as corners, corner exits and braking zones.

Step 1 - Set the rebound adjuster at mid-range.

Step 2 - Starting with the compression setting at mid-range, ride a lap then return. If the bike feels harsh, decrease the settings one click at a time until the harshness goes away. If the bike feels plush, increase the setting on click at a time until the bike becomes harsh, loses tire compliance and traction. At this point you know that you have gone too far on the compression settings; back off one click.

REBOUND

The idea is to tighten up the bike, stabilize the platform and eliminate the floating "Cadillac feeling". This will also reduce the rate of weight transfer.

Step 1 - With the rebound setting at mid-range, add 4 or clicks of rebound adjustment at a time, then return to continue the process until the bike becomes "skittish" or the rear wheel hops under braking. At this point you know you have gone too far on the rebound settings, back off one click at a time for final balance.

Once again, this is a basic procedure for finding your initial setup for a given track. If you find that you are at the end of your adjustment range and feel that the bike is feeling better, you will need to revalve the shocks to allow for further adjustment in the given direction.

Valving

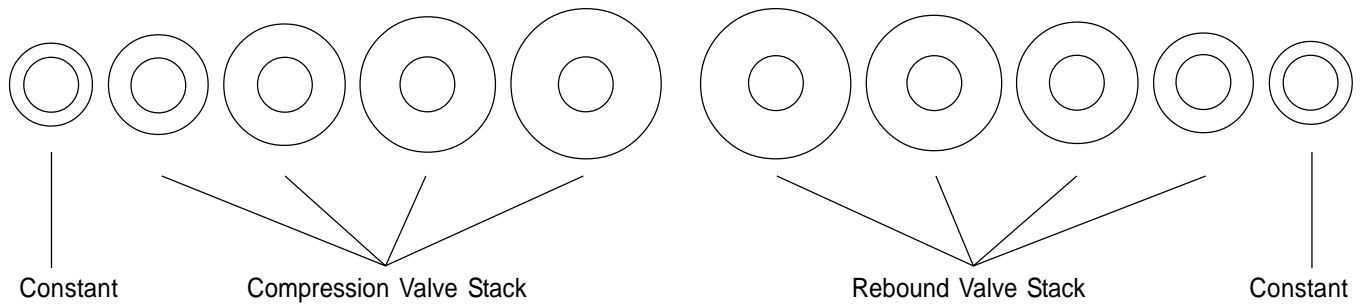

When referring to shock valving, (example: A/B), (A) refers to the compression valve stack and (B) refers to the rebound valve stack.

Valve Stacks

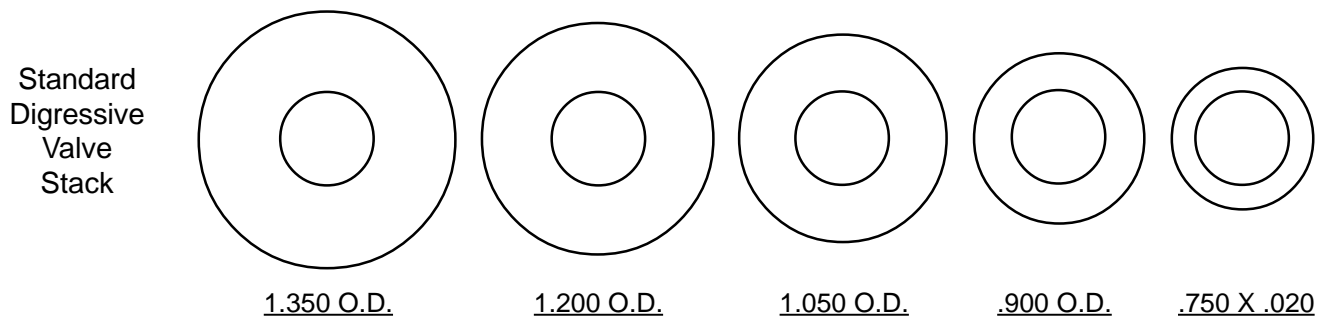

Part #						
VS-AA	AA	.004	.004	.004	.004	Constant
VS-AAP	AA+	.004	.004	.006	.006	Constant
VS-AM	A-	.006	.006	.004	.004	Constant
VS-A	A	.006	.006	.006	.006	Constant
VS-AP	A+	.006	.006	.008	.008	Constant
VS-BM	B-	.008	.008	.006	.006	Constant
VS-B	B	.008	.008	.008	.008	Constant
VS-BP	B+	.008	.008	.010	.010	Constant
VS-CM	C-	.010	.010	.008	.008	Constant
VS-C	C	.010	.010	.010	.010	Constant
VS-CP	C+	.010	.010	.012	.012	Constant
VS-DM	D-	.012	.012	.010	.010	Constant
VS-D	D	.012	.012	.012	.012	Constant
VS-DP	D+	.012	.012	.015	.015	Constant
VS-EM	E-	.015	.015	.012	.012	Constant
VS-E	E	.015	.015	.015	.015	Constant
VS-EP	E+	.015	.015	.020	.020	Constant
VS-FM	F-	.020	.020	.015	.015	Constant
VS-F	F	.020	.020	.020	.020	Constant

VDP and Digressive Valving Information Options

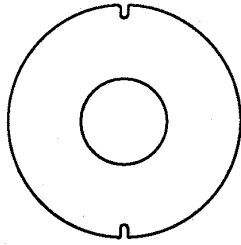

2 Notch
1.350 O.D.

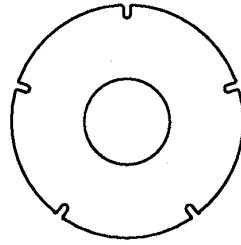

5 Notch
1.350 O.D.

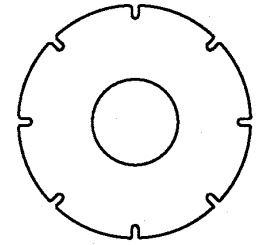

8 Notch
1.350 O.D.

Part #	Part #	Part#
.004 VW-2NX.004	.004 VW-5NX.004	.004 VW-8NX.004
.006 VW-2NX.006	.006 VW-5NX.006	.006 VW-8NX.006
.008 VW-2NX.008	.008 VW-5NX.008	.008 VW-8NX.008

Flow Rate Through Slotted Shims

Shim Thickness	Number of Notches	Relative Flow Rate	Equivalent Bleed Hole Ø (1) Hole
0.004	2	0.48	0.022
0.004	5	1.20	0.035
0.004	8	1.93	0.044
0.006	2	0.64	0.025
0.006	5	1.61	0.040
0.006	8	2.57	0.051
0.008	2	0.86	0.029
0.008	5	2.14	0.046
0.008	8	3.42	0.059

These flow rate values are dimensionless and have no real meaning by themselves. They are simply used to cross-reference the amount of flow between different bleed hole or slot combinations. For example, four Ø.010" holes would have the same flow rate as one Ø.020" hole (with a flow rate of 0.40). The flow rates can also be added, so a piston with three Ø.015" and three Ø.020" holes would have a total flow rate value of 0.68 + 1.20 = 1.88 which would be the same as three Ø.025" holes.

VDP 55mm Linear Base Shim

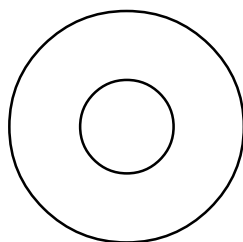

1.235 O.D.

Part #
.004 VS-37
.006 VS-39
.008 VS-41
.010 VS-43
.012 VS-45
.015 VS-47

Preload Shim Spacers

Part#
.004 x .750 VW-23
.006 x .750 VW-25
.008 x .750 VW-27
.010 x .750 VW-29
.012 x .750 VW-31
.015 x .750 VW-33
.020 x .750 VW-00

Flow Rate Through Multiple Bleed Holes

Hole Diameter	1 Hole	2 Holes	3 Holes	4 Holes	5 Holes	6 Holes	7 Holes	8 Holes	9 Holes
0.010	0.10	0.20	0.30	0.40	0.50	0.60	0.70	0.80	0.90
0.012	0.14	0.29	0.43	0.58	0.72	0.86	1.01	1.15	1.30
0.015	0.23	0.45	0.68	0.90	1.13	1.35	1.58	1.80	2.03
0.018	0.32	0.65	0.97	1.30	1.62	1.94	2.27	2.59	2.92
0.020	0.40	0.80	1.20	1.60	2.00	2.40	2.80	3.20	3.60
0.022	0.48	0.97	1.45	1.94	2.42	2.90	3.39	3.87	4.36
0.024	0.58	1.15	1.73	2.30	2.88	3.46	4.03	4.61	5.18
0.025	0.63	1.25	1.88	2.50	3.13	3.75	4.38	5.00	5.63
0.026	0.68	1.35	2.03	2.70	3.38	4.06	4.73	5.41	6.08
0.028	0.78	1.57	2.35	3.14	3.92	4.70	5.49	6.27	7.06
0.030	0.90	1.80	2.70	3.60	4.50	5.40	6.30	7.20	8.10
0.032	1.02	2.05	3.07	4.10	5.12	6.14	7.17	8.19	9.22
0.034	1.16	2.31	3.47	4.62	5.78	6.94	8.09	9.25	10.40
0.035	1.23	2.45	3.68	4.90	6.13	7.35	8.58	9.80	11.03
0.036	1.30	2.59	3.89	5.18	6.48	7.78	9.07	10.37	11.66
0.038	1.44	2.89	4.33	5.78	7.22	8.66	10.11	11.55	13.00
0.040	1.60	3.20	4.80	6.40	8.00	9.60	11.20	12.80	14.40
0.045	2.03	4.05	6.08	8.10	10.13	12.15	14.18	16.20	18.23
0.050	2.50	5.00	7.50	10.00	12.50	15.00	17.50	20.00	22.50
0.055	3.03	6.05	9.08	12.10	15.13	18.15	21.18	24.20	27.23
0.060	3.60	7.20	10.80	14.40	18.00	21.60	25.20	28.80	32.40
0.062	3.84	7.69	11.53	15.38	19.22	23.06	26.91	30.75	34.60
0.064	4.10	8.19	12.29	16.38	20.48	24.58	28.67	32.77	36.86
0.066	4.36	8.71	13.07	17.42	21.78	26.14	30.49	34.85	39.20
0.068	4.62	9.25	13.87	18.50	23.12	27.74	32.37	36.99	41.62
0.070	4.90	9.80	14.70	19.60	24.50	29.40	34.30	39.20	44.10
0.072	5.18	10.37	15.55	20.74	25.92	31.10	36.29	41.47	46.66

Piston Selection

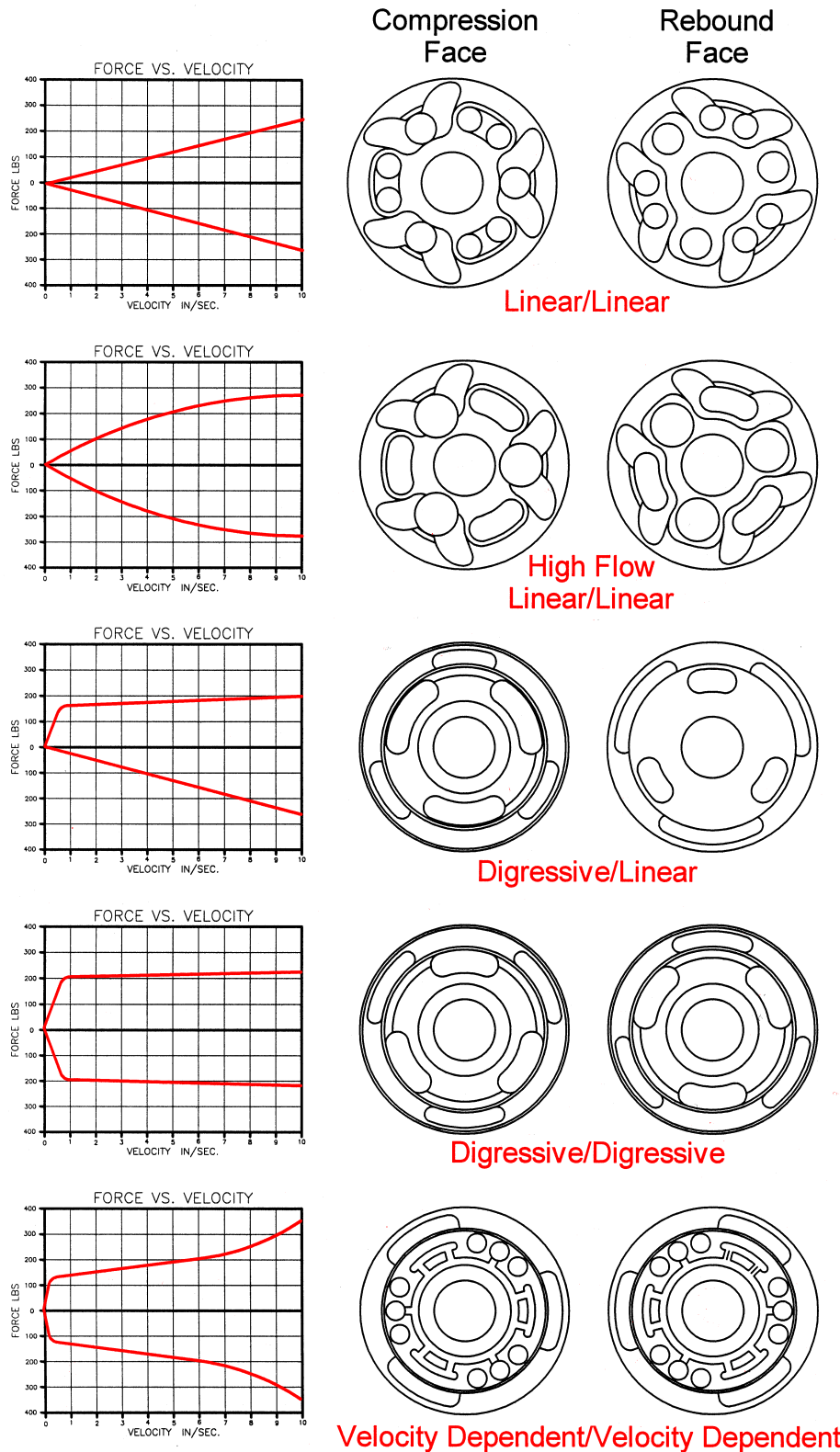

Digressive Blow Off

This two stage piston combines the low shaft speed characteristics of a linear piston with the blow off characteristic of a digressive piston at higher shaft speeds. Both parts of the curve are independently tunable.

COMPRESSION

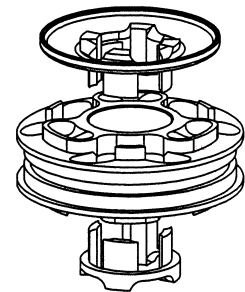

REBOUND

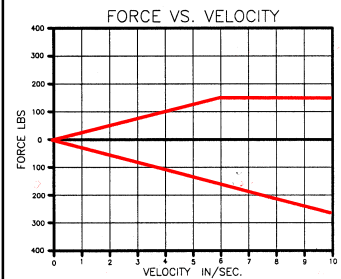

PART NO.	DESCRIPTION
PI-1100_*	Linear Piston, 1°/1°, (45mm or 55mm)
PI-1200_*	Linear Piston, 1°/2°, (45mm or 55mm)
PI-2100_*	Linear Piston, 2°/1°, (45mm or 55mm)
PI-2200_*	Linear Piston, 2°/2°, (45mm or 55mm)
PI-HF12005	High Flow Linear Piston, 1°/2°, 55mm
PI-HF14005	High Flow Linear Piston, 1°/4°, 55mm
PI-HF21005	High Flow Linear Piston, 2°/1°, 55mm
PI-HF22005	High Flow Linear Piston, 2°/2°, 55mm
PI-DL00_*	Digressive/Linear Piston, (45mm or 55mm)

PART NO.	DESCRIPTION
PI-DL005-1DG	Digressive/Linear Piston, 1°, 55mm
PI-DD00_*	Double Digressive Piston, (45mm or 55mm)
PI-VDL45	VDP / Linear Piston, 45mm
PI-VDPL55	VDP / Linear Piston, 55mm
PI-VDPL55-1DEG	VDP / Linear Piston, 1°, 55mm
PI-VDP5	Double VDP Piston, 55mm
PI-BLOWOFF-11	Blowoff Piston Complete, 1°/1°
PI-BLOWOFF-12	Blowoff Piston Complete, 1°/2°
PI-BLOWOFF-21	Blowoff Piston Complete, 2°/1°

* Incomplete Part Number

Linear Piston

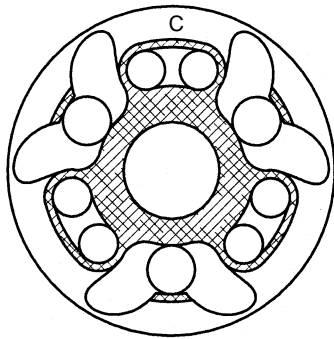

Compression Face

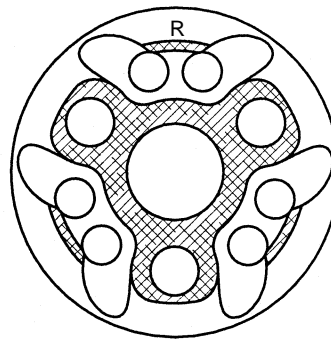

Rebound Face

 = Shim Sealing Surface

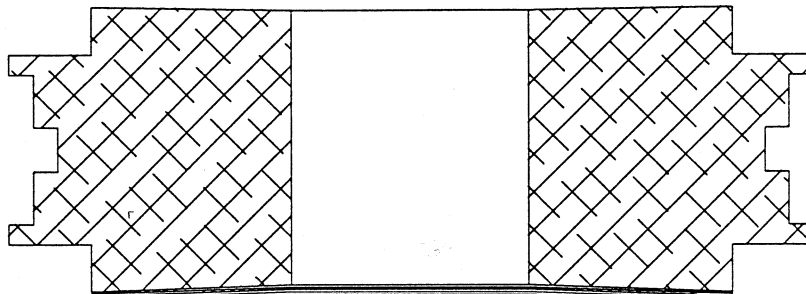

COMPRESSION VALVING
PRELOADED WITH 2° DISH

STANDARD 1° DISH

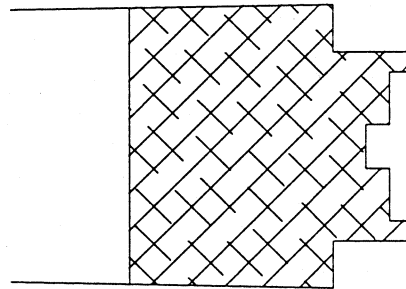
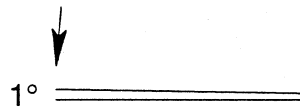

Each piston face has a dished surface, to preload the valve shims flat against the piston face. The standard dishing is 1° on both the compression and rebound sides of the piston. By increasing the compression side dishing to 2°, the shims become increasingly preloaded, causing a slight delay in opening during compression movement. The dishing causes the shims to “snap” open, in return giving the motorcycle a “snappier” feel as opposed to a smooth roll, once again this modification is for rider feel. If you have questions on piston dishing, call our technical staff for information and recommendations.

Digressive Piston

Digressive Piston

The "high flow" design incorporates larger ports on the face of the piston to increase the flow of oil throughout the shocks high speed action. When the shim stack opens, oil is "dumped" through the piston in large capacities. The increased flow of oil reduces the progressive damping characteristics of the linear side of the piston.

In addition to the larger ports, the face of the piston is designed to allow adjustments to the preload on the shim stack. Increased preload delays the opening of the shim stack, causing an increased damping force at low shaft speeds. When the shims crack open, oil is "dumped" at a high rate, reducing the progressive damping characteristics.

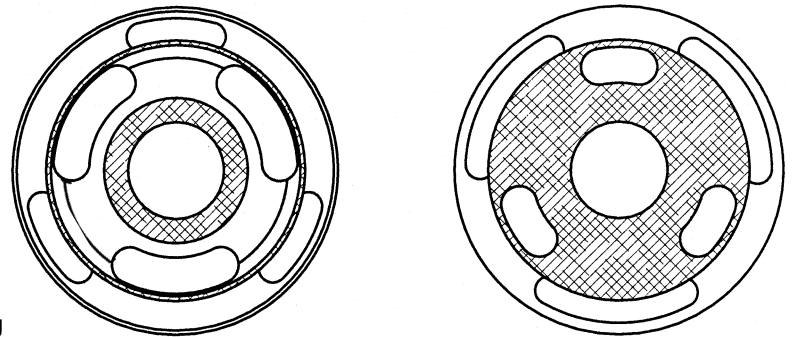

Digressive Face

Linear Face

To visually explain piston preload, Figure 3, shows a high flow piston with zero preload on the shim stack. Figure 4, shows a high flow piston with an exaggerated amount of preload. The preload cups the shim stack, energizing the shims until the instant high shaft velocity snaps them open. The preload may be varied by adding or subtracting a series of shims under the main shim stack.



FIGURE 3
NON-PRELOADED
SHIM STACK

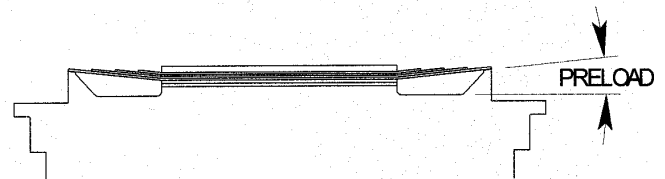

FIGURE 4
PRELOADED
SHIM STACK

The high flow piston design is offered in two variations. The double digressive piston is preload variable on both the compression and rebound sides. The digressive / linear piston is preload variable on the digressive side only, leaving the other side with linear characteristics. In most cases, the linear side of the piston would be rebound.

Digressive/Digressive

The double digressive piston has .050 (55mm), .030 (45mm) of available preload as shown in Figure 1. Stacking preload shims between the piston and the shim stack varies the amount of preload on the shim stack.

When referring to the amount of preload on a shim stack, you're referring to the amount of preload on the piston face of the shim stack. For example; 55mm .010 preload = .050 (total available preload) minus .040 (the combined thickness of the preload stack).

Digressive/Linear

The linear side of the digressive/linear piston is treated as a standard linear piston, using a standard valve stack with (5) backup shims. Due to the higher flow, it is a rule of thumb to run (1) step stiffer on the linear side than what was used on a standard linear piston (example: A up to B).

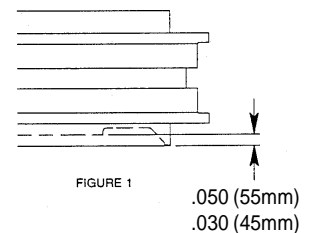
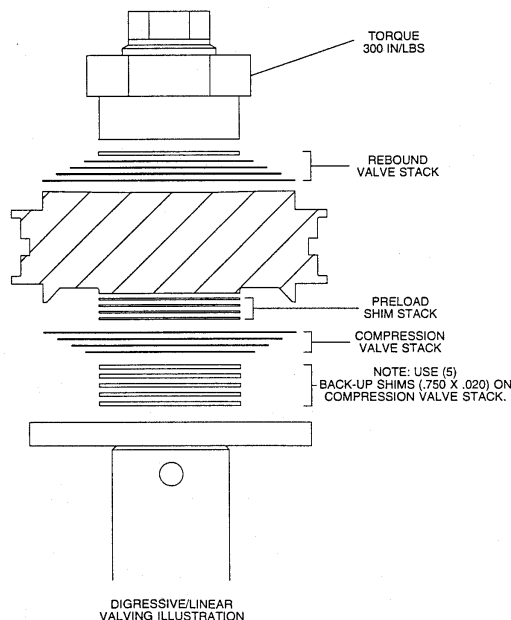
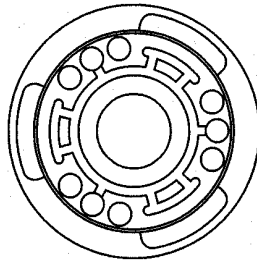

FIGURE 1

.050 (55mm)
.030 (45mm)

Velocity Dependent Piston (VDP)



Low Speed Bleed Path

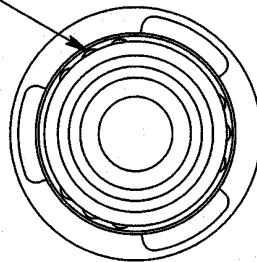

Digressive Shim Stack

O.D. Base Shim
01.235" for 55mm shocks
01.200" for 45mm shocks

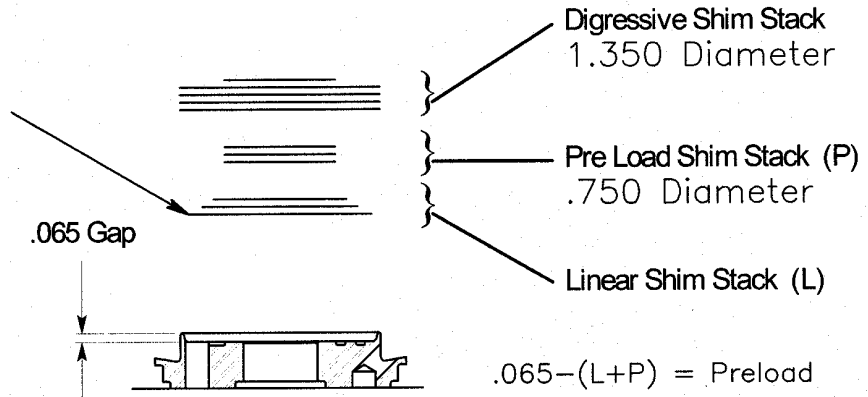

Velocity Dependent Piston (VDP)

Compression

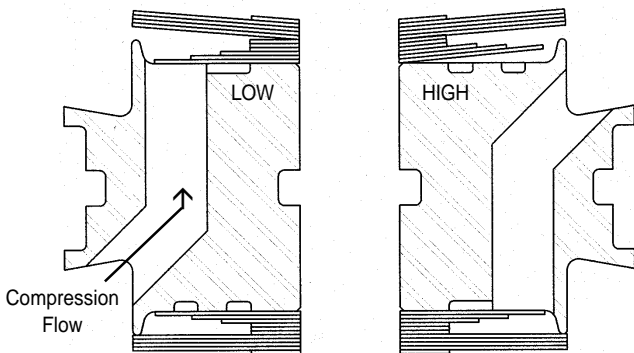

This graph illustrates the way in which the two different circuits operate on compression.

Rebound

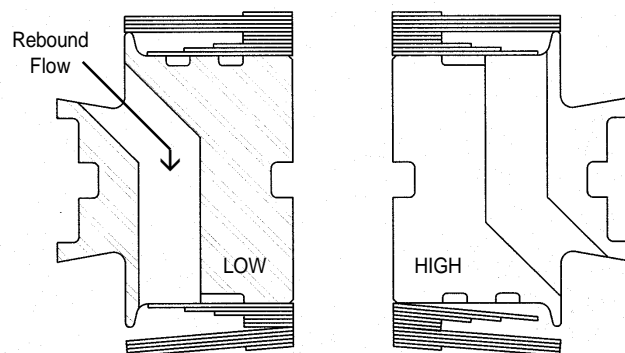

This graph illustrates the way in which the two different circuits operate on rebound side.

Low speed works the digressive stack and high speed works both.

Velocity Dependent Piston (VDP)

The Velocity Dependent Piston (VDP) has the unique ability to be valved to duplicate the curves of either linear or digressive pistons. Varying the inner, outer and preload stacks in conjunction with various bleed combinations can duplicate virtually any type of force value. Also the velocity where forces come in or out can be varied by altering the shims and preload/bleed combinations.

Note: On the VDP we have found that using all 1.350 shims for the digressive outer stack helps to separate the high and low speed circuits in the piston resulting in more compliancy over bumps and curbs.

1. The Low Speed section is controlled by the amount of bleed, the outer valve stack configuration and the amount of preload to determine the nose profile.
2. The Digressive profile is set by the thickness of the outer stack. The amount of time that the curve stays digressive is also influenced by the stiffness of the inner stack and when it is initiated is also controlled by the preload.
3. The Linear values and profile are set by the thickness of the inner stack.
4. The values and time of the progressive profile are determined by the orifice holes and the inner stack.

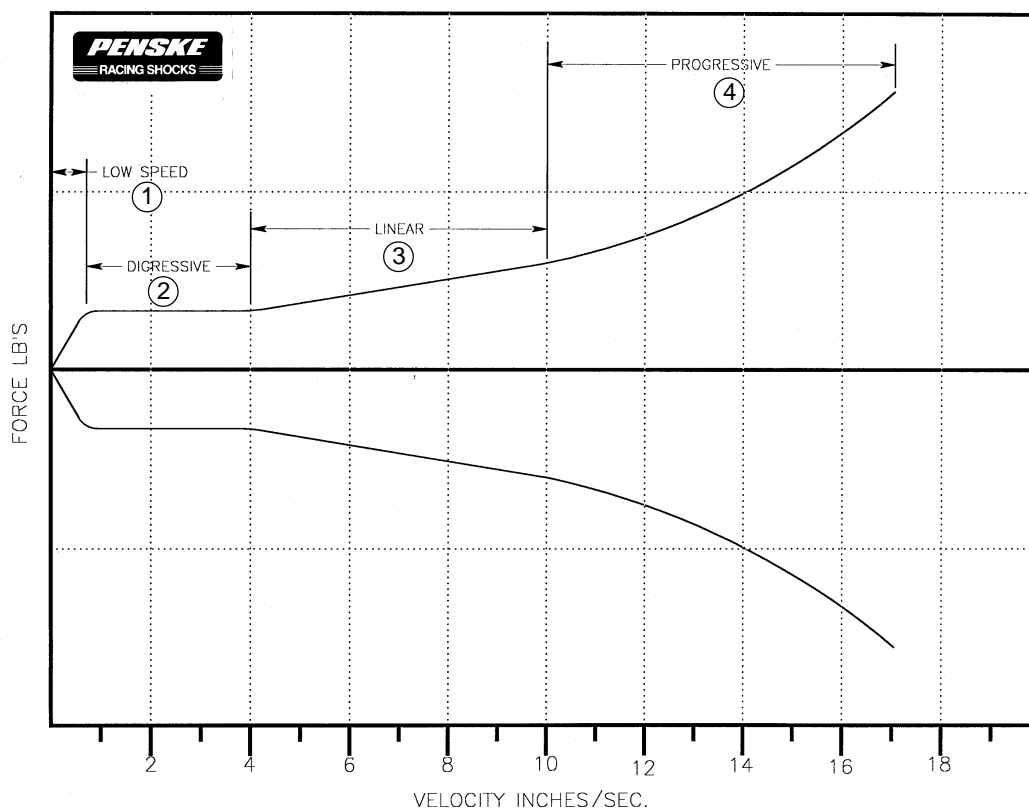

1. Low Speed - Bleed, Nose Profile
2. Digressive - Preload, Outer Stack

3. Linear - Inner Stack
4. Progressive - Orifice, Inner Stack

Damping Adjustments

There are three major ways in which you can vary the damping produced by the main piston: Shim stiffness, shim pre-load and the amount of bleed past the shims. These graphs help to visualize the way in which the damping is affected by each of these changes.

Figure 1 shows the effect of changing the pre-load (on digressive or VDP pistons) or dish (on linear pistons). Adding pre-load will create a lot more low speed damping. In compression, it will cause the tire to be loaded quicker and give a “snappy” feel. In rebound, it will help to tie the vehicle down and let it take a set quicker.

Figure 2 shows the effect of increasing the stiffness of the shim stack. Increasing the thickness of the shim stack (i.e., .004 to .010) stiffens the damping rate of the shock across the whole velocity range. While the other two adjustments only affect the lower shaft speeds, the shim stiffness is the best way to adjust damping at higher shaft speeds. The shims give the damping that chassis dynamics require.

Figure 3 shows the effect of adding bleed to the piston. Bleed is simply a low speed bypass for the shims and softens the shock at lower shaft speeds. This will improve the compliance of the bike to the ground under low amplitude movements which can improve grip. It will give the rider a softer ride, but will let the bike move more and take away support.

Figure 1

Pre-Load or Dish Adjustment

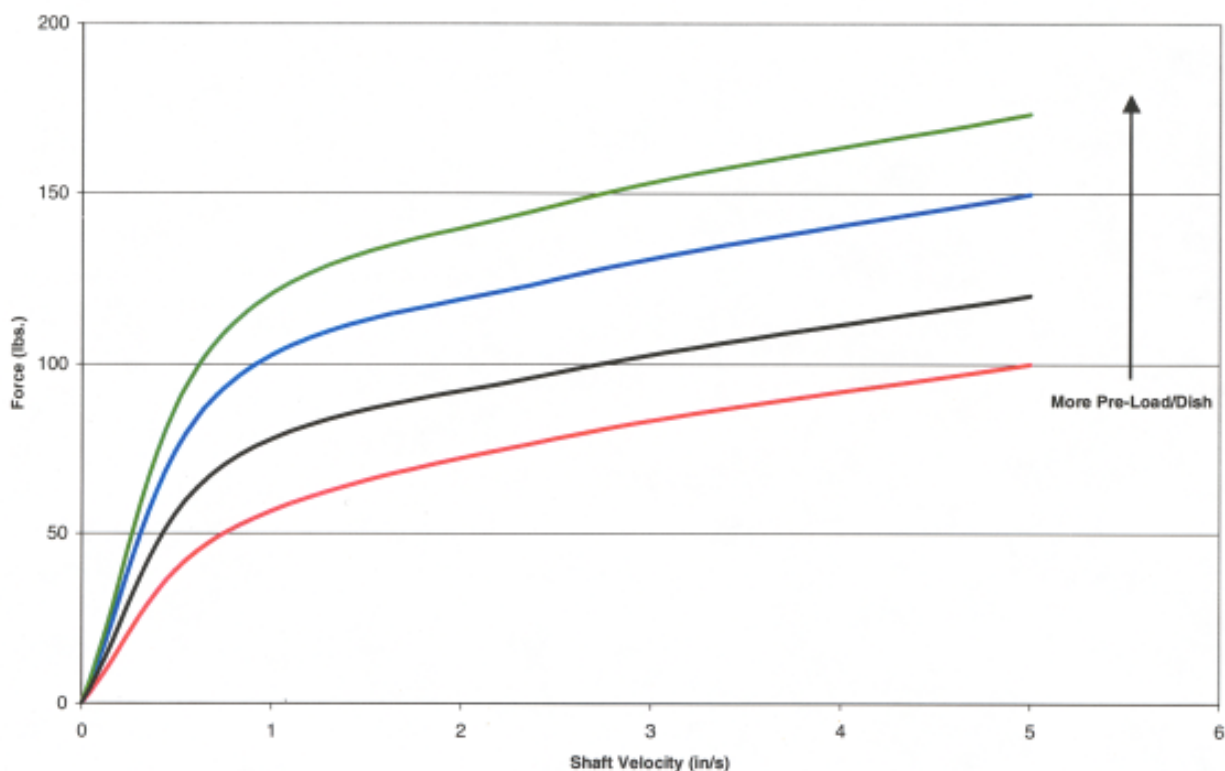

Damping Adjustments

Figure 2

Shim Adjustment

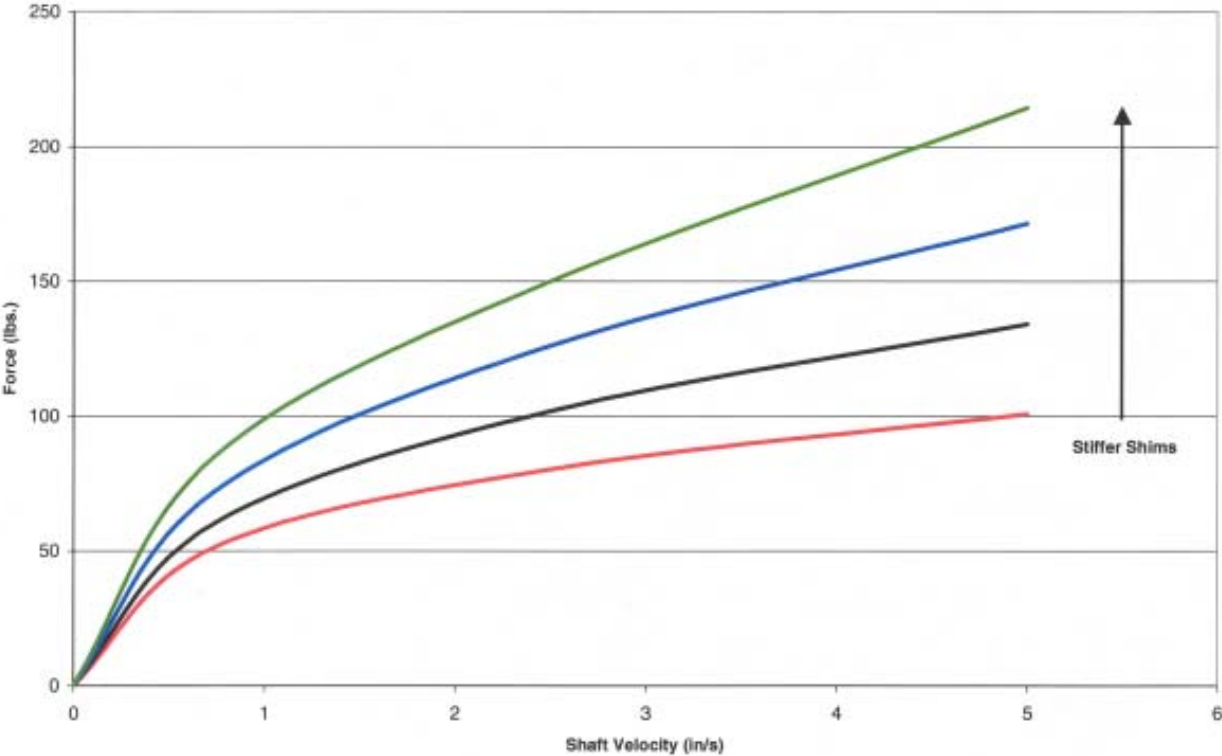
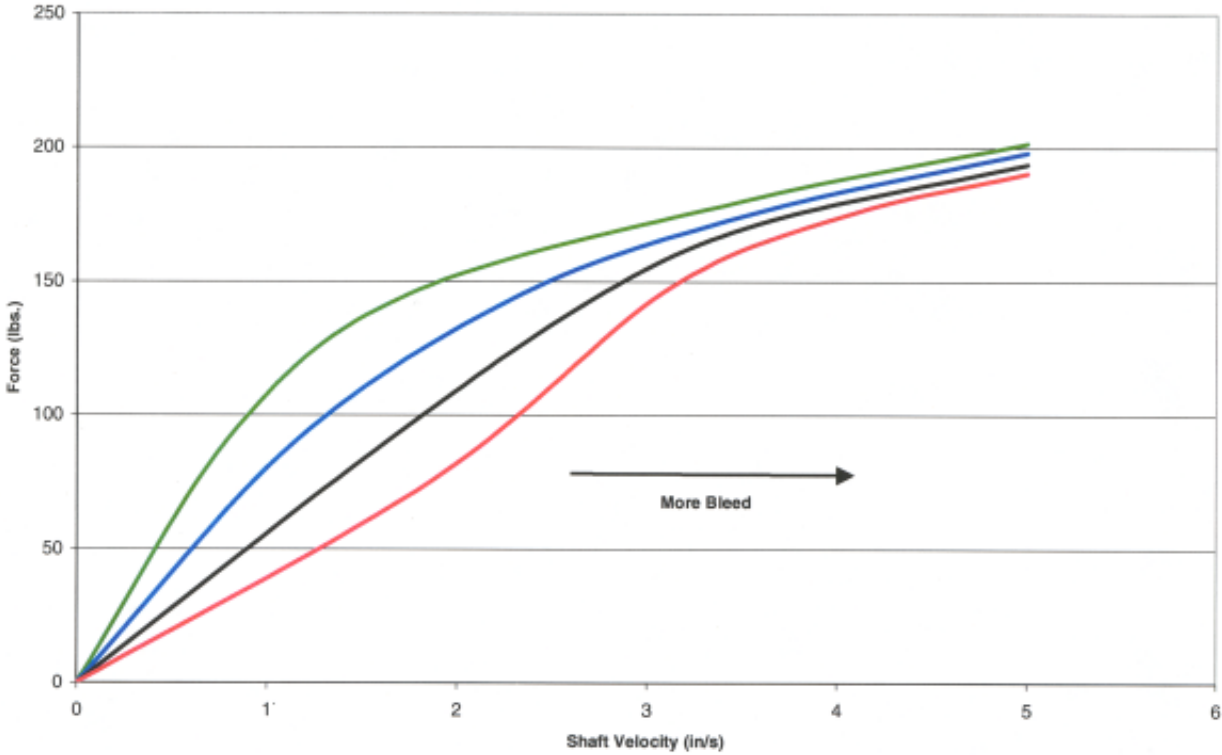
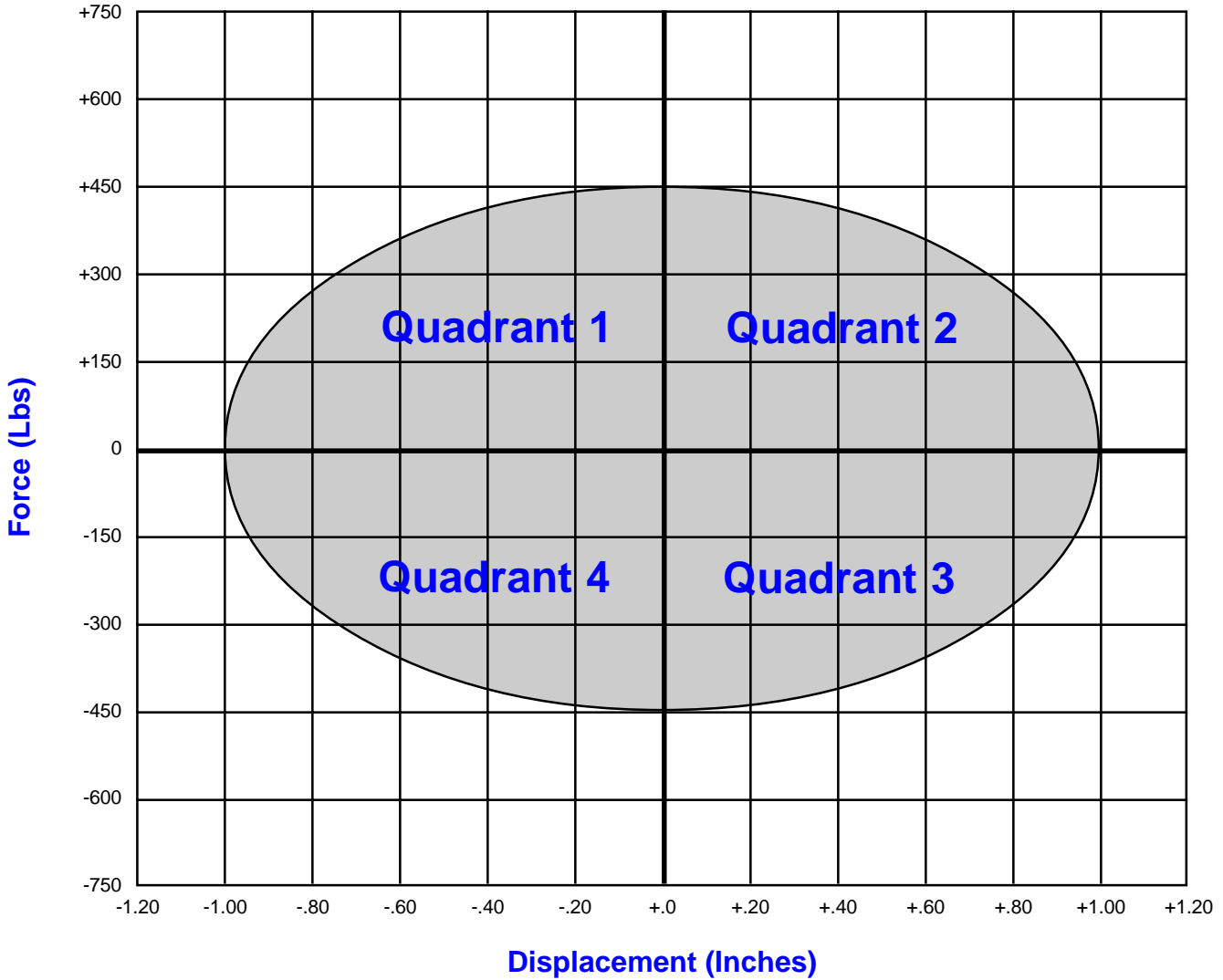

Figure 3

Bleed Adjustment



Dyno Graph Overview



This section of the manual illustrates different valving combinations in the form of graphs. The graph shown is force vs. displacement graph. The force vs. displacement graph is a very accurate and simple way to assess valving characteristics. If you are not familiar with this type of graph, it is explained on the following page along with the graph above, showing the four different quadrants.

Dyno Graph Overview

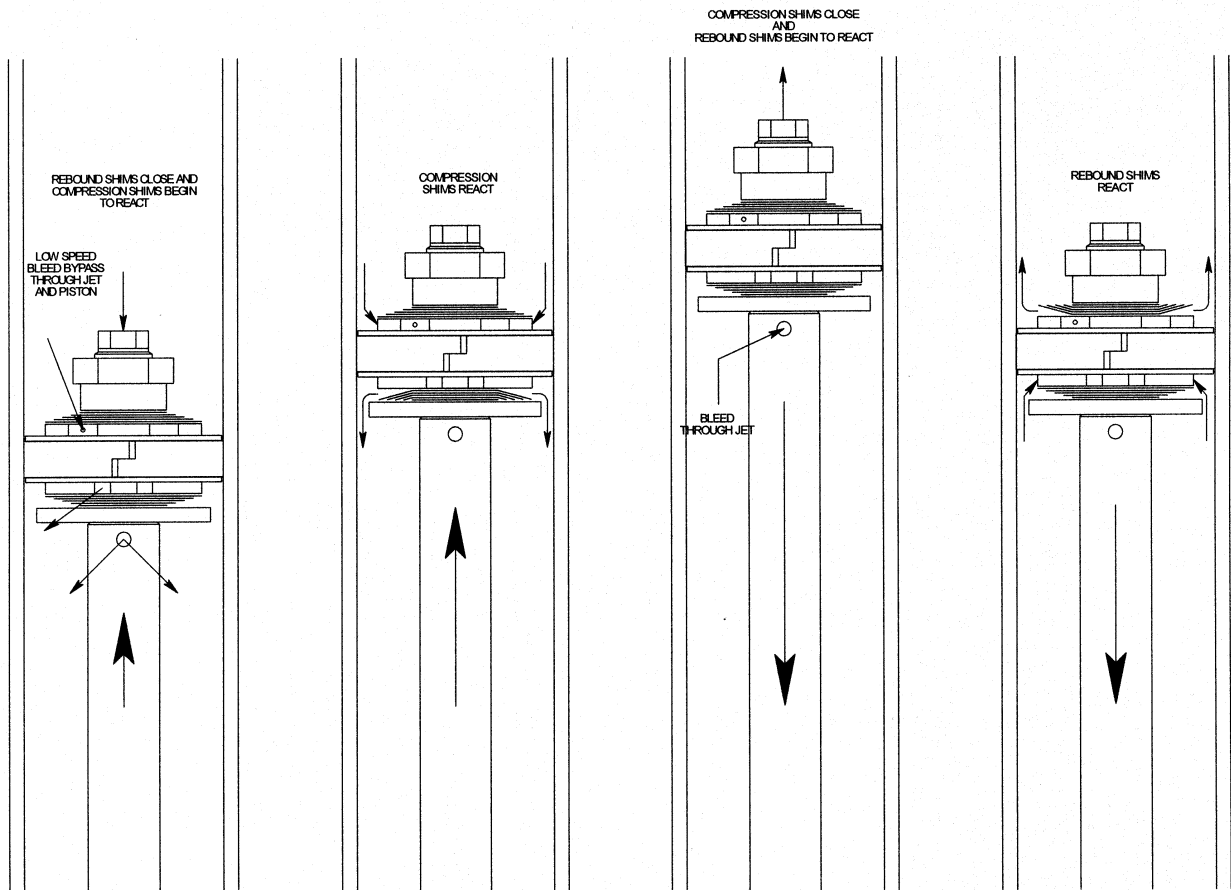

QUADRANT #1

This is the beginning of the compression stroke. Where the graph crosses the zero line (pounds) in quadrant #1 begins the compression stroke. Approximately the first 1/2" of displacement is formed with relation to the low speed bleed bypass. When the shaft reaches a certain velocity, the low speed bleed bypass shuts off and the compression valve stack begins to react.

QUADRANT #2

This quadrant begins with the compression valve stack open. Where the graph crosses the zero line (inches) in quadrant #2 is the maximum force produced by the compression valving. As the shock approaches the full compression point, the compression valve stack begins to close as it approaches the rebound movement.

QUADRANT #3

This quadrant begins with the shock at full compression and the compression valve stack closed. Where the graph crosses the zero line (pounds) in quadrant #3 begins the rebound stroke. Approximately the first 1/2" of displacement is formed with relation to the rebound bleed through the shaft and jet. When the shaft reaches a certain velocity, the bleed shuts off and the rebound valve stack begins to react.

QUADRANT #4

This quadrant begins with the rebound valve stack open. Where the graph crosses the zero line (inches) in quadrant #4 is the maximum force produced by the rebound valving. As the shock approaches the full extension point, the rebound valve stack begins to close as it approaches the compression movement. At this point the cycle starts over again in quadrant #1.

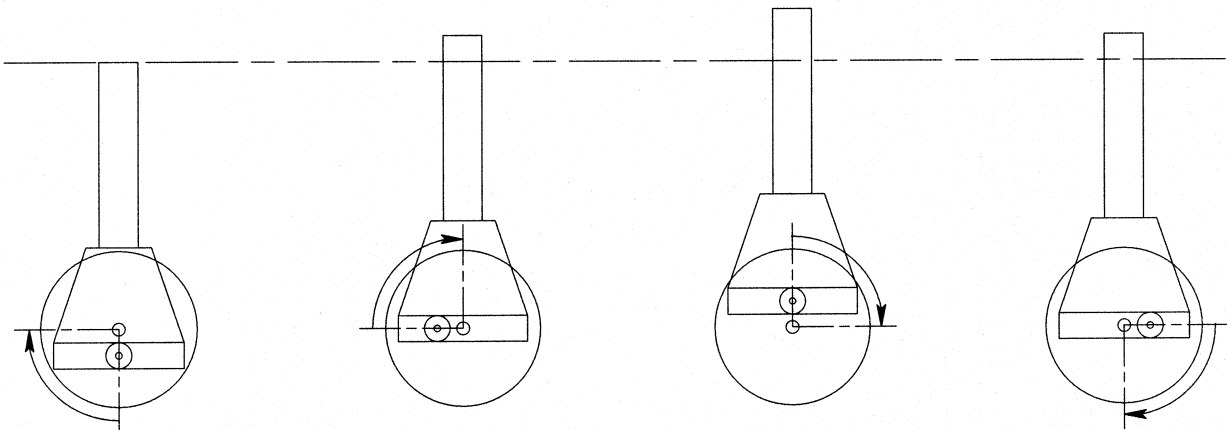

An easy way to help picture what is going on here is to relate the graph's shape to what the dyno is doing to the shock. The dyno uses a scotch yoke system (shown above), where the motor turns a crank and the sliding yoke allows the main dyno shaft to make the up and down movement at the preset stroke. The dyno software takes thousands of measurements throughout a single revolution of the crank. The sampled points are connected to form the graph. By relating the crank's position to the corresponding graph quadrant and the circular crank movement may help in reading the graphs.

Dyno Graph Overview



Penske Racing Shocks uses SPA Dynamometers because of its versatility and low speed metering and sample rates. Penske Shocks primarily uses the Force Average display, but SPA offers Decelerating CD/Accelerating RD and Accelerating CD/Decelerating RD viewing options for all its graph displays.

Force / Velocity Average

This graph shows the averages of the accelerating and decelerating compression and rebound forces. It is a good quick, general review of the shock curve, but is the least accurate of the options displayed.

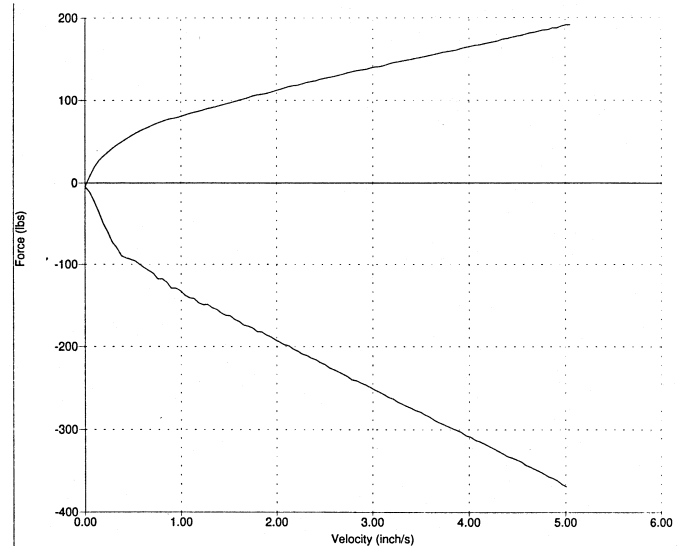

Force / Velocity

This graph displays the accelerating and decelerating compression and rebound forces. Think of this graph as the Force / Displacement graph (below) folded in half.

* Hysteresis is the gap between accelerating and decelerating compression and rebound damping. It is affected by the type of piston, the shims used and the relative position of high and low speed adjusters. The bleed hole will close the gap or soften the low speed forces.

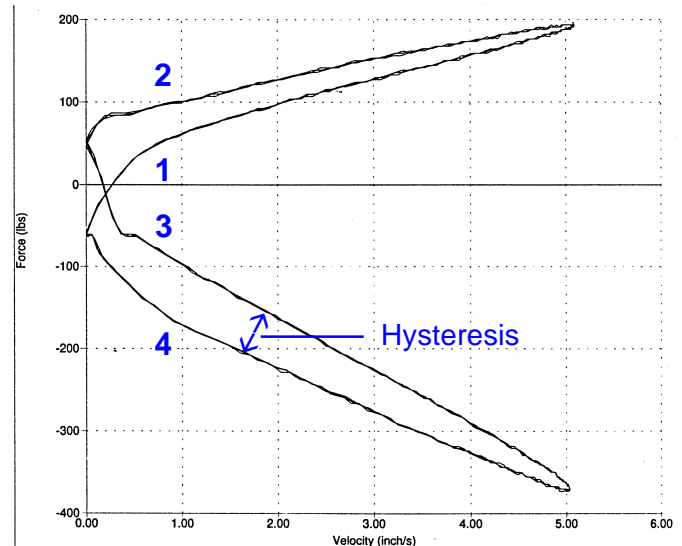

OVAL (Force / Displacement)

QUADRANT #1

This is the beginning of the compression stroke. Where the graph crosses the zero line (pounds) in quadrant #1 begins the compression stroke. Approximately the first 1/2" of displacement is formed with relation to the low speed bleed bypass. When the shaft reaches a certain velocity, the low speed bleed bypass chokes off and the compression valve stack begins to react.

QUADRANT #2

This quadrant begins with the compression valve stack open. Where the graph crosses the zero line (inches) in quadrant #2 is the maximum force produced by the compression valving. As the shock approaches the full compression point, the compression valve stack begins to close as it approaches the rebound movement.

QUADRANT #3

This quadrant begins with the shock at full compression and the compression valve stack closed. Where the graph crosses the zero line (pounds) in quadrant #3 begins the rebound stroke. Approximately the first 1/2" of displacement is formed with relation to the rebound bleed through the shaft and jet. When the shaft reaches a certain velocity, the bleed chokes off and the rebound valve stack begins to react.

QUADRANT #4

This quadrant begins with the rebound valve stack open. Where the graph crosses the zero line (inches) in quadrant #4 is the maximum force produced by the rebound valving. As the shock approaches the full extension point, the rebound valve stack begins to close as it approaches the compression movement. At this point the cycle starts over again in quadrant #1.

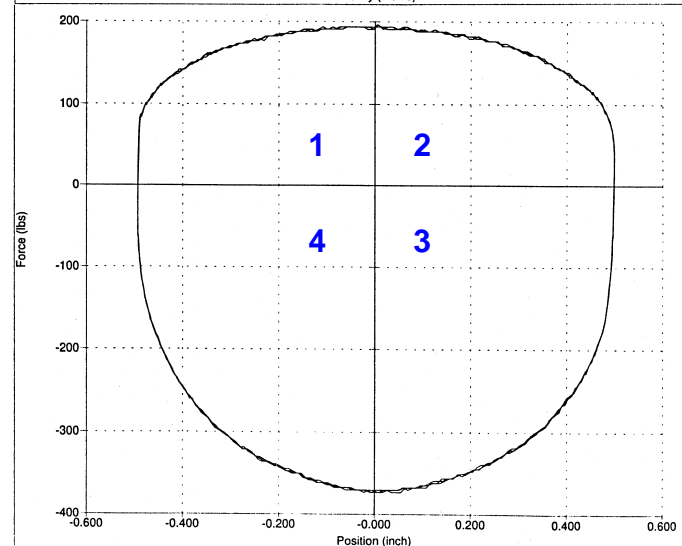

Dyno Graph Overview

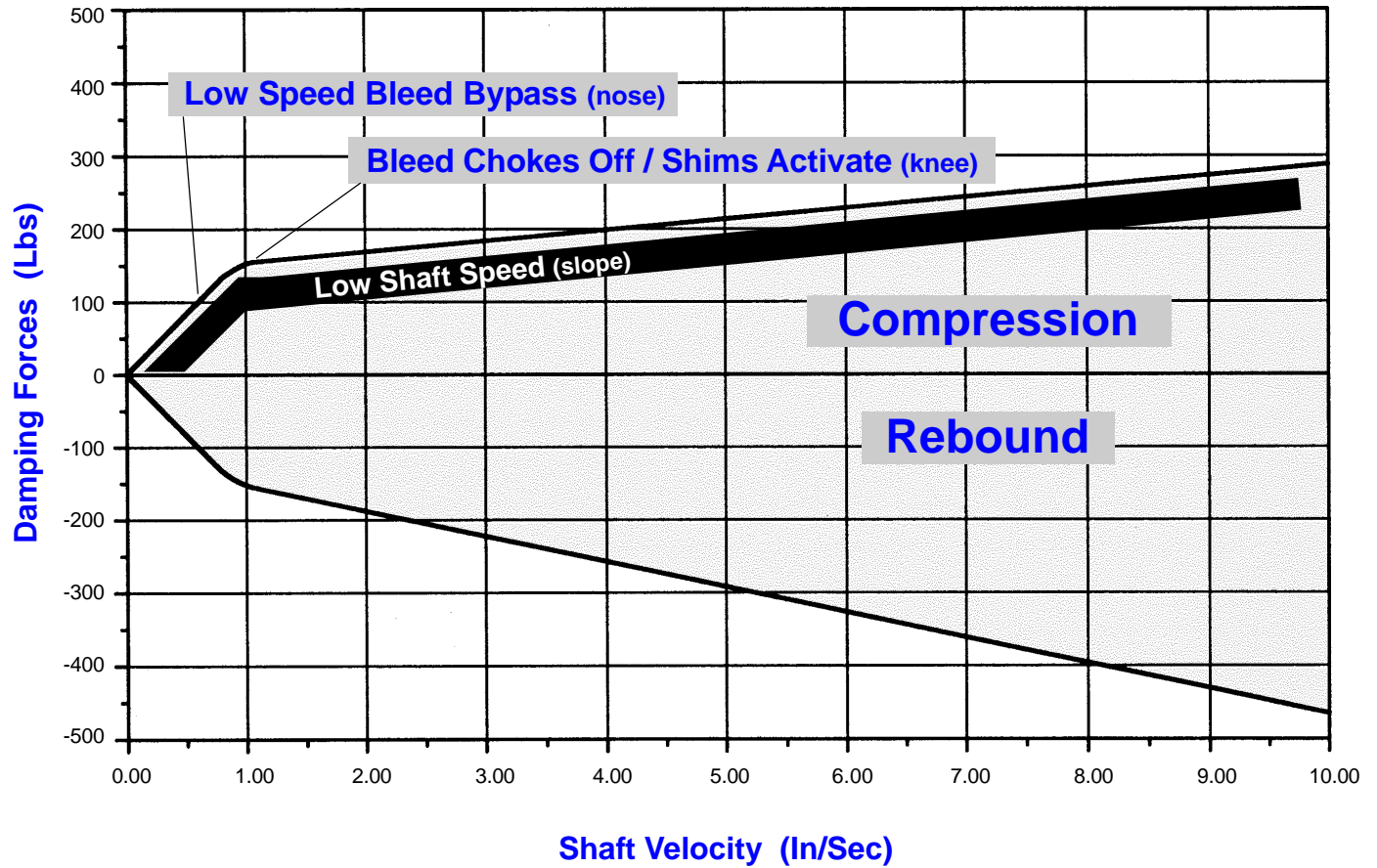

Note: Remember that low speed damping characteristics are controlled by bleed through the low speed adjuster and the bleed hole in the piston, not the valve stacks.

